

TKI NIEUW GAS
Topsector Energie

Overview of Hydrogen Projects in the Netherlands

Peter de Laat for TKI Nieuw Gas

May 2021



Introduction

Globally hydrogen projects are developing at a great speed. New projects are announced on a weekly basis. Dutch industry, research institutions, consultants, NGOs and governments actively take part in these developments and are jointly working on a large range of projects, aimed at realizing the potential role that hydrogen can play in the energy transition to carbon neutrality in 2050. These projects not only focus on The Netherlands, but also seek to connect to our neighboring countries, stakeholders in the North Sea region and to the global arena.

In this slide deck we present an overview of Dutch research, pilot and demonstration projects on hydrogen which are ready to be shared in the public domain. We hope that this overview of projects inspires everyone to continue working on the realization of these projects and start new ones. Of course this overview is not complete, it is just a picture of what is happening at this moment. If your project is not yet listed in this overview, or if the information presented is not accurate, please let us know so we can keep this overview up-to-date. Please contact us at office@tki-gas.nl.

Enjoy reading!

Jörg Gigler, managing director TKI New Gas | Topsector Energy



Explanation of the information box

- Category What is the main subject of the project in the hydrogen chain?
- Capacity What is the size of the project in MW, tons H₂/hour or trucks build?
- Process phase In which phase is the project:

concept	(idea development)
feasibility study	(first design)
FEED-study	(business case)
FID	(investment decision)
execution	(implementation, building)
commissioning	(test run)
- Project costs The amount of subsidy or investment involved.
- Contact Here, more information on the project or initiative is given.



Overview

TKI NIEUW GAS
Topsector Energie

Overview of Hydrogen Projects in the Netherlands
Peter de Laat for TKI Nieuw Gas

May 2021

Introduction

Globally hydrogen projects are developing at a great speed. New projects are announced on a weekly basis. Dutch industry, research institutions, consultants, NGOs and governments actively take part in these developments and are jointly working on a large range of projects, aimed at realizing the potential role that hydrogen can play in the energy transition to carbon neutrality in 2050. These projects not only focus on The Netherlands, but also seek to connect to our neighboring countries, stakeholders in the North Sea region and to the global arena.

In this slide deck we present an overview of Dutch research, pilot and demonstration projects on hydrogen which are ready to be shared in the public domain. We hope that this overview of projects inspires everyone to continue working on the realization of these projects and start new ones. Of course this overview is not complete, it is just a picture of what is happening at this moment. If your project is not yet listed in this overview, or if the information presented is not accurate, please let us know so we can keep this overview up-to-date. Please contact us at info@tki-gas.nl.

Enjoy reading!

Jörg Oglet, managing director TKI New Gas | Topsector Energie

Explanation of the information box

- Category** What is the main subject of the project in the hydrogen chain?
- Capacity** What is the size of the project in MW, tons H₂/hour or trucks built?
- Process phase** In which phase is the project:
 - concept (idea development)
 - feasibility study (first design)
 - FEED-study (business case)
 - PII (investment decision)
 - execution (implementation, building)
 - commissioning (test run)
- Project costs** The amount of subsidy or investment involved.
- Contact** Here, more information on the project or initiative is given.

Production

Storage

Transportation

Distribution

Deployment: Energy Supply

Deployment: Industrial

Deployment: Mobility

Deployment: Built Environment

Knowledge



Production

Overview

A 3x4 grid of 12 small thumbnail images representing different stages or components of the production process. The thumbnails include various charts, diagrams, and text blocks, likely representing different stages of the production process.



Production I

A 4x5 grid of 20 small thumbnail images representing different stages or components of the production process. The thumbnails include various charts, diagrams, and text blocks, likely representing different stages of the production process.



Production II

A 4x4 grid of 16 small thumbnail images representing different stages or components of the production process. The thumbnails include various charts, diagrams, and text blocks, likely representing different stages of the production process.



Production III

A 4x4 grid of 16 small thumbnail images representing different stages or components of the production process. The thumbnails include various charts, diagrams, and text blocks, likely representing different stages of the production process.



Production II

Overview

Production I

Production III

H2ARVESTER

Harvesting Extra Hydrogen on Agricultural Land in Use

The mobile H2ARVESTER can be used as an 'extra crop' in the rotational cultivation of arable farmers. The yield of the solar panels can be processed into hydrogen (H₂) and stored, to balance the production and use of the generated energy.

Category:	production of hydrogen
Capacity:	variable
Process phase:	concept
Project period:	2017 - 2021
Project costs:	unknown
Contact:	h2arvester@rak.nl

Partners: LTO noord, Rijkswaterstaat, TNO, Wageningen UR

Bio-TechH₂

Production of Bio-Hydrogen

Creating the basis for an implementation of biobutanol production from biogenic waste streams and wastewater with smart bacteria in fermentation tanks. Upscaling to large-scale technology to realize the development step of a market-ready establishment.

Category:	production of biobutanol
Capacity:	variable
Process phase:	POCD study
Project period:	2018 - 2022
Project costs:	300+ internat industry
Contact:	www.biohydrogen.nl/forrest

Partners: Universiteit van Twente, Eindhoven University of Technology, BioEnergy Cluster, PlanE, H2or

Djewels-1

Realisation of a 20 MW Electrolyser in Delfzijl

Operated by Nouryon and Gasunie, it will provide 3,000 tons of green hydrogen per year, reducing CO₂ emissions by 27,000 tons per year. The produced hydrogen will be used for green methanol production for transport fuel at DSM/N. This plant also must validate the technical integrity and operating processes, capacity and safety of a large-scale water electrolyser plant.

Category:	production of hydrogen
Capacity:	20 MW
Process phase:	POCD study
Project period:	2024 -
Project costs:	100 MW study
Contact:	www.gasunie.nl/weg1

Partners: Nouryon, Gasunie, DSM, MCFPV, H2or, DE NOVA

H2-Fifty

Building a 250 MW Electrolysis Plant in Port of Rotterdam

The new factory will be able to produce 40,000 tons of green hydrogen annually. Because the hydrogen is produced from water with sustainable electricity, CO₂ emissions are almost zero. The plant will use the green hydrogen to produce methanol and mobility products. The H2-Fifty project will be in the so-called Cavenham Park, a special site that the Port Authority is building on the Maasvlakte for electrolysis from natural gas.

Category:	production of H ₂
Capacity:	250 MW
Process phase:	POCD study
Project period:	2018 - 2022 (POCD)
Project costs:	225 - 300 M
Contact:	h2fifty@portofrotterdam.nl

Partners: Port of Rotterdam, Nouryon

Porthos

CCUS Infrastructure for Blue Hydrogen in Port of Rotterdam

Tensile of green hydrogen production at the Delta site of Air Products in the Port of Rotterdam into blue H₂ CO₂ into the North Sea bottom. The CO₂ will be transported through an offshore pipeline to a platform in the North Sea, representing 20 km off the coast. From this platform, the CO₂ will be injected in an empty gas field. The empty gas fields are situated in a water reservoir of porous sandstone, more than 3 km beneath the North Sea. It is expected that the system will be operational by 2025.

Category:	production of blue H ₂
Capacity:	2.8 million tce CO ₂ per year
Process phase:	POCD study, POCD 2022
Project period:	2023 - 2029
Project costs:	2.8 B USD + 1.20 B USD study
Contact:	www.porthos.nl

Partners: Air Products, ExxonMobil, Shell, Enbridge, H2or, Liquide Gasunie

Eernshydrogen

Building a 50 MW Hydrogen Plant for Westereems Wind Farm

The Eernshydrogen project demonstrates at scale (50MW) that electrolyzers can flexibly follow intermittent power production from a directly connected wind farm. The electrolyser supports development of a large hydrogen infrastructure and targets CO₂ reduction in heat to stable industrial sectors. Depending on market conditions and regulations, the electrolyser capacity will be scaled up further.

Category:	production of green H ₂
Capacity:	50 MW
Process phase:	conceptual design
Project period:	POCD in 2024
Contact:	www.eernshydrogen.nl/en

Partners: WATTENFALL, Enbridge

Hy4Am

Building a 10 MW Electrolyser at Hemweg Location

The goal is to locally approximately 200 kg/hour green hydrogen in mobility and industry in the Amsterdam region from 2024. The technical feasibility study has been successfully completed and the focus is currently on developing market demand and refining the business case. This plan is the first part of a local free hub (production, storage and distribution) for producing green electricity, heating and fuels for Amsterdam's Westpoort Region.

Category:	production of H ₂
Capacity:	10 MW, 200 kg/h
Process phase:	feasibility study finished
Project period:	2018 - 2024, POCD in 2022
Contact:	www.vdfcc.nl/en/10

Partners: WATTENFALL, Port of Amsterdam

H-vision

A Unique Approach for Industry to Achieve its Climate Targets with Low-CO₂ Hydrogen

Mixing together the full hydrogen value chain, to deliver 2.7 Mton of CO₂ emissions reductions for the Rotterdam industry by 2030. With two world-scale hydrogen plants, capturing over 90% of the CO₂ emissions. The unique process uses refinery fuel gas as its primary feedstock. The low-carbon hydrogen will have a purity of over 99%.

Category:	production of low-CO ₂ Hydrogen
Capacity:	2 plants of 150 MW concept
Process phase:	2024 - 2032
Project period:	2024 - 2032
Project costs:	1-2 B investment
Contact:	kapsen@h2vision.nl

Partners: Shell, Air Products, H2or, OXYS

GreenH2UB

Creating a Green Hydrogen Ecosystem in North-Brabant

GreenH2UB is a 5-10 MW green hydrogen plant based on POCD production. Application and deployment in industry, mobility and built environment. The realization of the first GreenH2UB is led by the KSP in the Midden-Region Cluster. The GreenH2UB will be connected directly to wind farms in Park and order farms. Provided the Contract Design and obtained a positive Feasibility Study.

Category:	production of green H ₂
Capacity:	5-10 MW (2024-2025)
Process phase:	POCD study
Project period:	POCD 2022, CO2 2023
Project costs:	400-1200 M USD
Contact:	www.greenh2ub.nl

Partners: FORCE, BOM, Borealis, H2or, HyEnergy

HEAVENN

H₂ Energy Applications in Valley Environments for Northern NL

The project's support focus on sectoral synergy: the large-scale production of green hydrogen as a raw material for industry, the storage, transport and distribution of hydrogen and its application for energy, except for both industry and the built environment and mobility.

Category:	production H ₂ in Energy Valley
Capacity:	30 MW capacity
Process phase:	POCD study
Project period:	2020 - 2025
Project costs:	90 M
Contact:	New Energy Coalition

Partners: Shell, Air Products, H2or, OXYS, TNO, Wageningen UR

Hydrogen Delta

Shift of the Largest Hydrogen Producer (500kta) and Consumer in the Benelux to a Sustainable Hydrogen Cluster.

The Hydrogen Delta Program aims to make industry more sustainable by steering out grey hydrogen into blue hydrogen (CO₂) and green hydrogen. In addition, efforts are made to use yellow hydrogen (renewable) and, when appropriate, orange hydrogen (renewable). This by producing green hydrogen on a large scale, ensuring it locally and ensuring well-expected. The next step is to build and the kick-start of green hydrogen plants.

Category:	production, distribution
Capacity:	1-1.5 GW projects
Process phase:	POCD study
Project period:	2020 - 2028
Project costs:	1-1.5 B
Contact:	www.hydrogendelta.eu

Partners: Shell, Air Products, H2or, OXYS, TNO, Wageningen UR

GZI NEXT

A Second Life for the GZI Site in Emmen, with Hydrogen

Together they look at the possibilities of using the existing infrastructure for the generation of green gas through fermentation or gasification and for the generation of hydrogen. In 2025, previous of Drenthe order 10 hydrogen buses and a 10 MW electrolyser is planned to lead them.

Category:	production, distribution
Capacity:	10 MW
Process phase:	POCD study
Project period:	2025 -
Project costs:	1.5 M provincial subsidy
Contact:	aweg@emmen.nl

Partners: GASPHU, H2or, OXYS

Bio Energy Netherlands

Wood Gasification with Production of Hydrogen and CO₂

The wood gasification plant in Amstelveen will extract hydrogen and CO₂ from the syngas, which can be used for transport fuels and in the chemical industry, amongst others. Developing and testing a gas upgrading system linked to a gasifier for production of green hydrogen.

Category:	production
Capacity:	-
Process phase:	POCD study
Project period:	2018 - 2023
Project costs:	TSC 500 k
Contact:	info@bioenergy.nl

Partners: Bio Energy Netherlands, HYGEAR



Production III

Overview

Production I

Production II

Hydrogen Mill

Building a Windmill that Produces Hydrogen

Two 4.5 MW ENERCON windmills will be built in 2021 and a 2.1 MW electrolyser will be integrated in 2022. The goal of this project is to create synergy between the wind turbine, electrolyser and pipeline & storage. The demonstrator hybrid turbine will be built on the ECH test location in the Wieringermeer.

Category	production, storage, distribution
Capacity	2 MW
Process phase	execution
Project period	2021 - 2022
Project code	HydroMill
Contact	info@h2-gro.nl

Partners: ENERCON, New Energy Gateway, HYGRO, TNO

PosHYdon

Hydrogen Production from North Sea Water on an Offshore Platform

A 1 MW electrolyser in a sea container on the platform, the O2 is very suitable for this. It is a fully stock-listed offshore platform. This stock-listed platform with green electricity saves 16.3 kJ of CO₂ per tonne.

Category	production of H ₂
Capacity	1 MW
Process phase	POCD study
Project period	2019 - 2021
Project code	Uthmaniyah
Contact	patrick.schouten@tandemenergy.com

Partners: Tandem Energy, H2Gate, TNO

H2ermes

Building a 100 MW Hydrogen Plant in Amsterdam for TaTa Steel

Deployment of hydrogen delivered by a 100 MW electrolysis plant to produce basic and / or basic chemicals with the carbon monoxide (CO) and carbon dioxide (CO₂) in the residual gases from the steel production at TaTa Steel.

Category	production
Capacity	100 MW
Process phase	POCD study
Project period	2018 -
Project code	100 M
Contact	Henk.van.Hoek@tatasteel.nl

Partners: TATA STEEL, Nouryon

Molten Metal Methane Pyrolysis

Producing 'Turquoise' Hydrogen from Natural Gas

Methane pyrolysis produces hydrogen from natural gas with carbon (and red CO₂) as a valuable by-product. Affordable and commercially applicable within a few years. The applications are diverse. Think of additive for steel, filler in car tires, graphite, dye and soil conditioner.

Category	production, knowledge
Capacity	available
Process phase	POCD
Project period	2019 - 2020
Project code	Uthmaniyah
Contact	william.frens@tno.nl

Partners: TNO, VOLTA CHEM

GH2

Producing Hydrogen by Gasification of Biomass in 'het Groene Hart'

The pilot plant of initially 1 kg H₂/day, the size of four parking spaces, is located at Vermeulen Groep, a civil engineering company. Green gas and wood waste is used for heating. The pilot will serve the design of a 300 kg H₂/day production plant using 10 ton/day biomass. On an annual basis that is 3000 tonnes. The gasifier of the production plant will be 2 MW thermal and we produce 1 ton/day of biochar per day which is equal to 3 tonnes of CO₂ equivalent stored. The production of 300 kg hydrogen requires a 1.2 MW steam boiler which requires a 202.8 MW installed capacity of 180 tonnes oil. The hydrogen obtained is partly used by Vermeulen Groep, who wants to make their business more sustainable.

Category	production of H ₂
Capacity	300 kg/day (1.2 MW)
Process phase	POCD study
Project period	2016 - 2022
Contact	info@gh2.nl

Partners: NETT Energy, VERMEULEN GROEP

NorthH2

The Production of Green Hydrogen from a GW Windfarm in the North Sea

The objective is to generate 0.6 to 0.8 GWh of green hydrogen per year, and possibly 1.5 GWh in 2040. Green hydrogen production of 80,000 tons, prevents around 7 megatonnes of CO₂ emissions per year. The final concept will be selected in mid-2022 and then further developed towards an investment decision in 2024.

Category	production of H ₂
Capacity	0.6 - 0.8 MWh/y
Process phase	POCD study
Project period	2020 - 2040
Project code	Uthmaniyah
Contact	info@northh2.nl

Partners: gas2h2, E.ON Energy Research Center, H2Gate, Equinor, TNO, Shell, Pragma

HyNetherlands

Building a 100 MW Electrolyser in the Eemshaven

The factory will also have an important function for the balance in the electricity system. If the wind farms supply more electricity than is currently needed, it can be converted into hydrogen and stored. If necessary, the hydrogen can be converted back into electricity. ENH is now engaged in the preparatory activities for taking the final investment decision for the 100MW electrolyser at the end of 2021. Commissioning is scheduled for 2024.

Category	production of hydrogen
Capacity	150 MW for 1 GW
Process phase	POCD study
Project period	2021 - 2022
Project code	50 - 100 M
Contact	www.enh.nl/enh-016/projection/hy/netherlands

Partners: gas2h2, ENH, GETEC, M&E Energy

H2-Gateway

Empty Gas Fields Play a Role for Blue Hydrogen Production

The hydrogen gas can be produced with green energy from the large offshore wind farms that will be built in the coming decades. But even now hydrogen can be produced from natural gas. The released CO₂ can be captured and stored in the empty gas fields below the North Sea.

Category	production of H ₂
Capacity	0.2 Mtpa
Process phase	POCD study
Project period	2020 - 2025
Project code	600 M auto
Contact	Thijs.Paerink@rdg.nl

Partners: TNO, Shell, Equinor, H2Gate, Pragma, E.ON Energy Research Center, M&E Energy, GETEC

GldH2

A Hydrogen Value-Chain with Multi Purpose in Zutphen

Integral use of locally generated green hydrogen in Zutphen, among others for heating central houses in the city center, using existing gas pipelines and freight rail central loading facilities. In addition, also for industrial use and mobility, including heavy transport and public transport.

Category	production and deployment
Capacity	2.888 electrolyser
Process phase	POCD study
Project period	2020 - 2023
Project code	480A
Contact	www.gldh2.nl

Partners: PRIMAGAZ, ZUTPHEN, H2Gate, TNO, Shell, Pragma, E.ON Energy Research Center, M&E Energy, GETEC

Hydrogen Mill Sint Philipsland

To Use Profits to Benefit the Livability of the Community

The initiators of the windmill look for an alternative for the local electricity grid. The use of the national natural gas network for storage, distribution and deployment of their own production of hydrogen. Therefore, they hope to make the peninsula Sint Philipsland a hydrogen village.

Category	production
Capacity	1 MW
Process phase	POCD study
Project period	2020 - 2022
Project code	225 k study
Contact	http://www.oceanenergy.nl/sintphilipsland

Partners: STPHILIPS, STEDIM GROUP, ZINNOVIC, BlueTerra Energy Coopers



Energiepark Eemshaven-West

Combining four Technologies to Produce Renewable Hydrogen

Vattenfall aims to produce 100% renewable hydrogen in the area of Eemshaven-West, in Northern Netherlands, by connecting wind and solar electricity production directly to an electrolyser and a battery, in order to decarbonize the mobility and industry sector. The renewable hydrogen will initially be produced with a 10 MW electrolyser (2024), after which a ramp-up will take place towards 100 MW by 2027.



Category:	production of H ₂
Capacity:	10 MW(2024) -100 MW(2027)
Process phase:	FEED-study (permitting phase)
Project period:	2020 – 2023, FID in 2023
Contact:	www.vattenfall.com/nl

VATTENFALL 



ELYgator

Building a 200MW Electrolyser in Terneuzen

Energy Air Liquide intends to develop the ELYgator, a large-scale 200MW water electrolyser project that will be entirely sourced from renewable power sources and will enable avoidance of 4M tons of CO₂ over the first 10 years of the plant's operation. The unit is planned to become operational in 2024 and produce over 18 ktons of renewable hydrogen per year which will be injected into Air Liquide's European cross-border hydrogen network and dedicated to both mobility applications as well as industrial applications.



Category:	production of H ₂
Capacity:	200 MW
Process phase:	FEED-study
Project period:	2020 – 2024
Project costs:	€ 270 - 290M
Contact:	michael.depauw@airliquide.com



H2 Conversion Park

Building First 2 GW Conversion Park for Large Scale Hydrogen Production on the Maasvlakte in Rotterdam

Several large-scale hydrogen factories will produce hydrogen on this central location and share at least electricity and hydrogen infrastructure. From this central location hydrogen will be transported via the open-access hydrogen backbone towards companies in the Port of Rotterdam. The first electrolyzers announced in the conversion park are the 150-250MW of Shell (2023) and 250MW of H2-Fifty (BP and Nouryon; 2025).

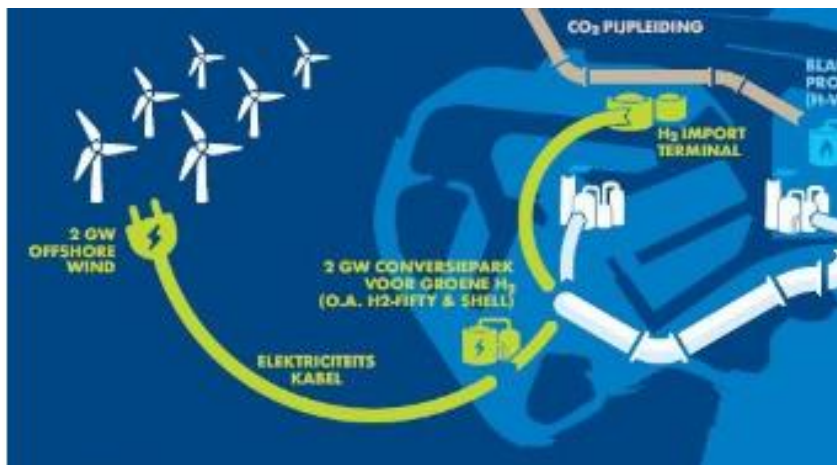

Category:	production of H ₂
Capacity:	1-2 GW
Process phase:	concept
Project period:	2020 – 2050
Project costs:	unknown
Contact:	rfm.weterings@portofrotterdam.com

Partners:



H2Gate

Import of Megatons of Green Hydrogen in Amsterdam

H2Gate focuses on the development of large-scale hydrogen imports to the Amsterdam port region (1 million ton per year). The project focuses on several hydrogen carriers that match the infrastructure in the port. The expected result of the first step is a blueprint that reveals the potential and challenges for large-scale green hydrogen import, and a roadmap that identifies concrete next steps for the development of a demonstration project. The first phase of the project will run to July 2021. The aim for the realization of the import terminal is around 2030.



Category:	production of H ₂ by import, storage
Capacity:	1 Mton/ year
Process phase:	Feasibility-study
Project period:	2021 – 2030
Project costs:	unknown
Contact:	Eduard.de.Visser@portofamsterdam.com

Partners:



H₂ero

Hydrogen out of Energy of Renewable Origin for Zeeland

The project initially consists of a feasibility study into a 150 MW electrolyser on the site of Zeeland Refinery in Vlissingen. This location is particularly suitable given its location in an already highly hydrogen-intensive region with many opportunities for setting up and scaling up a 'low-carbon' hydrogen value chain. An annual production of 23 kT of green hydrogen can be expected with the installation, which is equivalent to an avoided CO₂-emission of approximately 200 kTa compared to H₂ production through the conventional fossil route.



Category:	production of H ₂
Capacity:	150 MW
Process phase:	Feasibility-study
Project period:	2021 – 2026
Project costs:	unknown
Contact:	koen.van-leuven@zrefinery.nl

Partners:



Pilotplant of First High-Temperature Electrolyser (HTE) System

MULTIPLHY thus aims to install, integrate and operate the world's first high-temperature electrolyser system in multi-megawatt-scale, at a biofuels refinery in Rotterdam to produce hydrogen for the refinery's processes. MULTIPLHY's electrical efficiency (85 %el, LHV) will be at least 20 % higher than efficiencies of low temperature electrolysers, enabling the cutting of operational costs and the reduction of the connected load at the refinery and hence the impact on the local power grid.

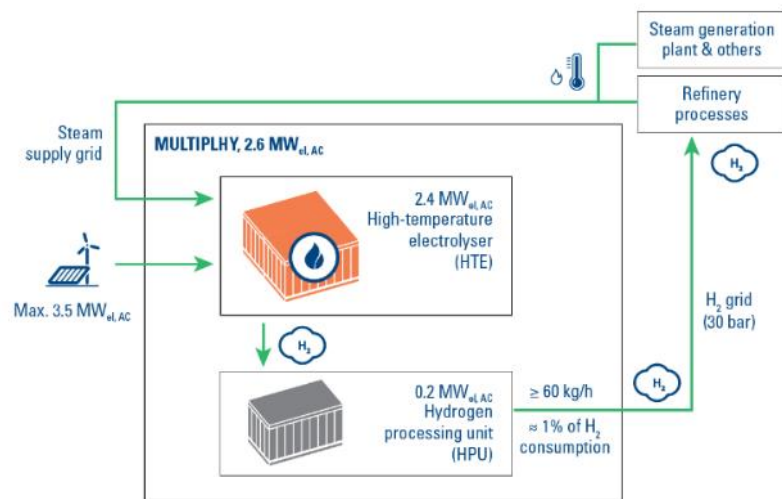

Category:	production of H ₂
Capacity:	2.6 MW / 60 kg/h
Process phase:	execution, operational Q2 2022
Project period:	2020 – 2024
Project costs:	9.75M€
Contact:	https://multiplhy-project.eu

Partners:



FUREC

Hydrogen Production Plant by 'waste-to-chemicals' on Chemelot

The project plans to transform residual waste into raw material pellets, which are then converted into hydrogen at industrial park Chemelot. FUREC (Fuse Reuse Recycle) uses existing waste streams, partly of biogenic origin, so that they do not have to be landfilled or incinerated. FUREC saves the equivalent of 140.000 households of natural gas use. In addition to local sales at Chemelot, the hydrogen can eventually be transported to industry in Rotterdam and the German Ruhr area. The CO₂ released during the production of hydrogen can be either captured and stored or used as a raw material in the future.



Category:	production of H ₂
Capacity:	200 Mio m ³ a.e.
Process phase:	Feasibility-study
Project period:	2021 – 2025
Contact:	denis.aarssen@rwe.com

OCI



chemelot
for today's future

provincie limburg



Production of H₂ through Gasification of Torrefied Biomass

The aim is to demonstrate the feasibility of hydrogen production via the gasification of bio-raw materials, where the carbon is applied in the form of BioCO₂ and BioChar, on an industrial scale. The company BrigH2 develops on Brightlands Chemelot Campus a 50 MW pilotplant with the use of Torrgas technology and aims to produce green hydrogen and bioCO₂ on a MW scale by 2024.

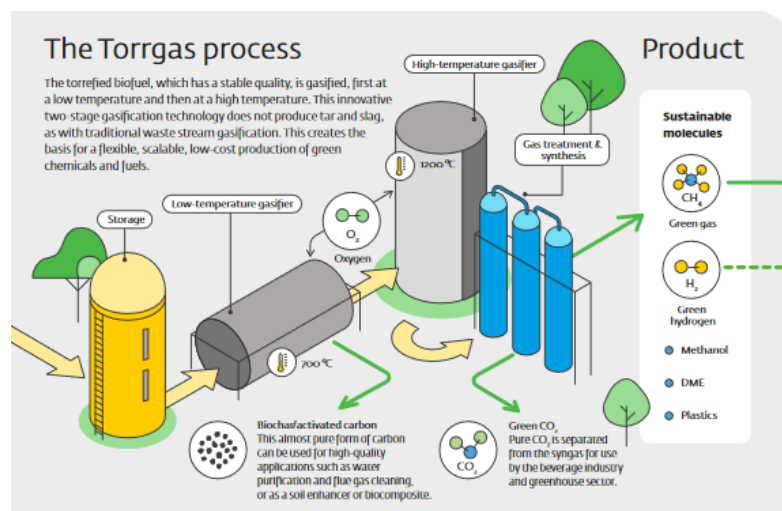

Category:	production of H ₂
Capacity:	50 MW
Process phase:	FEED-study
Project period:	2020 – 2025
Project costs:	unknown
Contact:	Marc.VanDoorn@brightlands.com

Partners:



Haddock

Building a 100 MW Electrolysis Plant on Yara-site in Sluiskil

The aim of the project is to replace fossil hydrogen, mainly produced from natural gas, with renewable hydrogen to produce 75,000 tons of green ammonia a year. That is approximately 10 percent of the capacity of the largest of the ammonia plants in Sluiskil. The green ammonia is intended to be used in the production of carbon neutral fertilizer products, decarbonizing the food value chain, and also has potential as a future climate neutral shipping fuel. The installation is powered by dedicated renewable energy supply from Ørsted's offshore wind farms.



Category:	production of H ₂
Capacity:	100 MW
Process phase:	Feasibility-study
Project period:	2020 – 2025
Project costs:	unknown
Contact:	www.yara.nl

Partners:



Knowledge grows



SeaH2Land

Linking GW-scale Electrolysis to the Large Industrial Demand in the Dutch-Flemish North Sea Port Cluster Through an Envisaged Regional Cross-Border Pipeline.

SeaH2Land is a vision for gigawatt-scale electrolysis and offshore wind landing points on both sides of the river Scheldt after extension of the 380kV grid, turning the cluster into a true hydrogen hub. Containing a 1 GW electrolyser to produce renewable hydrogen, 2 GW of new offshore wind capacity linked to the electrolyser and 45 kilometres of regional hydrogen pipelines between the Netherlands and Belgium to exchange hydrogen between industrial players in the region.



Category:	production of H ₂
Capacity:	1 GW
Process phase:	Feasibility-study
Project period:	2020 – 2030
Project costs:	unknown
Contact:	https://seah2land.nl/

Partners:



Knowledge grows



H2Agro

2 Agricultural Companies Work Together Towards a Sustainable Future with Hydrogen

Arable and flower bulb company Vof Dogterom on Goeree-Overflakkee and arable farming company Vof van den Hoek in Hoeksche Waard started their own research in 2018 into making the farm more sustainable using hydrogen. Now Accenda B.V. simulating and designing an optimized energy system for each company. With a simulation, the available production of sustainable energy is mapped out over time, including the own energy consumption. The required capacity of the electrolyser is calculated based on the available sustainable energy for hydrogen production.



Category:	production of H ₂ , storage, use
Capacity:	under study
Process phase:	FEED-study
Project period:	2018 – 2022
Contact:	wveefkind@ltonoord.nl

Partners:



CurtHyl

Building a 10 MW Electrolyser to Avoid Curtailment Windpark

The project CurtHyl in the Port of Rotterdam aims to make use of the renewable electricity from Vattenfall's existing onshore windfarm Slufterdam, which would be partly curtailed due to a grid bottleneck, to produce 100% renewable hydrogen via electrolysis. This hydrogen is to be distributed via an existing hydrogen pipeline owned and operated by Air Liquide. In the next phase, starting operation from 2025, the production shall be increased to a 100 MW electrolyser or more with electricity supply possibly from windfarm Hollandse Kust Zuid.



Category:	production of H ₂
Capacity:	10 - 100 MW
Process phase:	FEED-study
Project period:	2020 – 2023,
Project costs:	unknown
Contact:	www.vattenfall.com/nl

Partners:

VATTENFALL 

 **Port of
Rotterdam**

 **Air Liquide**



VoltH2

Hydrogen Production with Storage & Distribution Facilities

Developing an initial 25 MW green hydrogen production plant next to the Sloe central Powerplant in Vlissingen, using electrolyzers powered only by renewable energy sources. The facility will have dedicated hydrogen storage and access to multimodal transport systems to support the distribution of H₂ beyond the immediate locality. VoltH2 will assess the feasibility of installing an onsite H₂ fueling station for the supply of hydrogen directly to lorries, trucks and other vehicles. The project will be designed to be scalable in phases, up to a target of 100 MW by 2030.

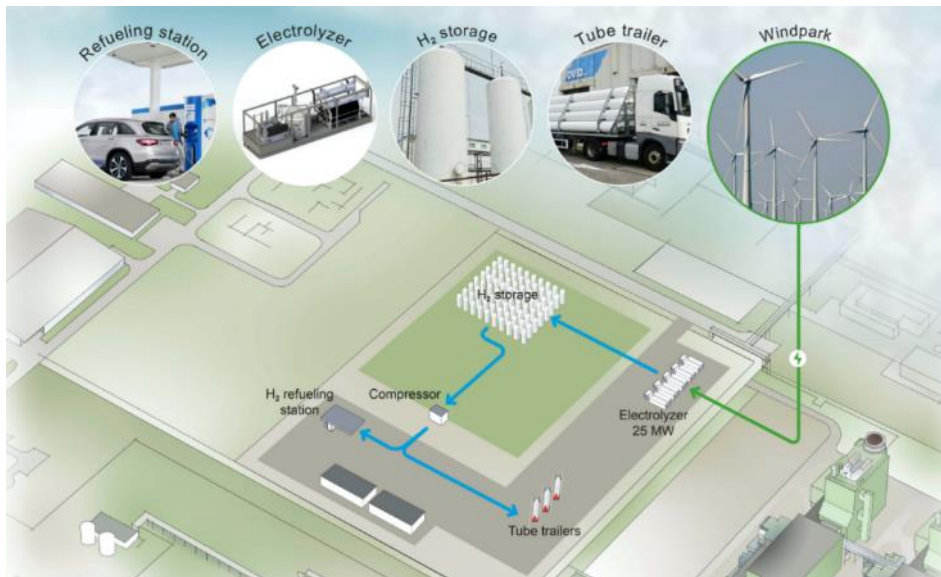

Category:	production of H ₂
Capacity:	25 MW
Process phase:	FEED-study
Project period:	2020 – 2024
Project costs:	35M
Contact:	www.volth2.com



Uniper

Building a 100 MW Electrolysis Plant on the Maasvlakte

Energy company Uniper and the Port of Rotterdam Authority are investigating the possibilities for large-scale production of green hydrogen on the Maasvlakte. The ambition is to realize a hydrogen plant with a capacity of 100 MW on the Uniper site by 2025 and eventually expand that capacity to 500 MW. The Maasvlakte is an excellent location to produce green hydrogen. Renewable electricity from offshore wind farms will soon be landed here and various important facilities are already present on the Uniper site.



Category:	production of H ₂
Capacity:	100 MW
Process phase:	Feasibility-study
Project period:	2021 – 2025
Project costs:	unknown
Contact:	fred.hage@uniper.energy

Partners:



The Rotterdam Electrolyser

Realisation of ~200 MW Electrolyser in Rotterdam

The green hydrogen produced will initially be used at the Shell refinery in Pernis to partially decarbonise the production of fossil fuels. This saves a minimum of 200,000 tonnes of CO₂ per year. This hydrogen can later be used to decarbonise trucks in the transport sector.

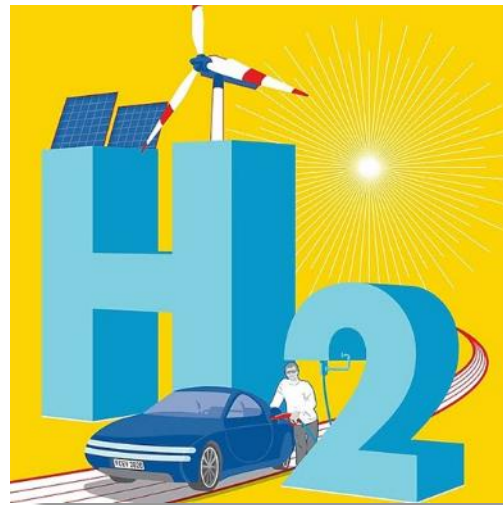

Category:	production of hydrogen
Capacity:	200 MW / 50,000 kg H ₂ /day
Process phase:	FEED-study, FID 2021
Project period:	2020 - 2023
Project costs:	unknown
Contact:	Imtiaas.Ramdjanbeg@shell.com

Partners:



Hydrohub GW

The Hydrohub GigaWatt Scale Electrolyser

Conceptual design of a many - electrolyser system of gigawatt size - the size that bridges large-scale renewable power production in offshore wind parks and industrial-scale use of hydrogen for feedstock and energy purposes.



Category:	production of H ₂
Capacity:	1 GW
Process phase:	FEED-study
Project period:	2018 - 2021
Project costs:	TKI subsidy
Contact:	carol.xiao@ispt.eu

Partners:



GROHW

Designing a Local Scalable Hydrogen System Together

We want to have impact as a green hydrogen accelerator. That means we look at the most viable scenario for local green hydrogen, oxygen and heat production and utilization and make this scenario scalable by developing a blueprint for our approach and design. A PEM electrolyser coupled to a gas-fired adsorption heat pump and Energy Flex Platform is being prepared for a 50-kW demonstration of the hydrogen system. Through this demonstration, we aim for first steps in CO₂ emission reduction in the built environment and industry.



Category:	production of green hydrogen
Capacity:	MW
Process phase:	execution, demonstration
Project period:	2020 - 2023
Project costs:	3-4 million
Contact:	raphael.van.der.velde@witteveenbos.com

Partners:



H2ARVESTER

Harvesting Extra Hydrogen on Agricultural Land in Use

The mobile H2ARVESTER can be seen as an "extra crop" in the rotational cultivation of arable farmers. The yield of the solar panels can be processed into hydrogen (H₂) and stored, to balance the production and use of the generated energy.



Category:	production of hydrogen
Capacity:	scalable
Process phase:	concept
Project period:	2017 - 2021
Project costs:	unknown
Contact:	mvroom@npk.nl

Partners:



npk | design

L'Orèl Consultancy
B.V.



Production of Bio-Hydrogen

Creating the basis for an implementation of biohydrogen production from biogenic waste streams and wastewater with smart bacteria in fermentation tanks. Upscaling to large-scale technology to realize the development step of a market-ready establishment.

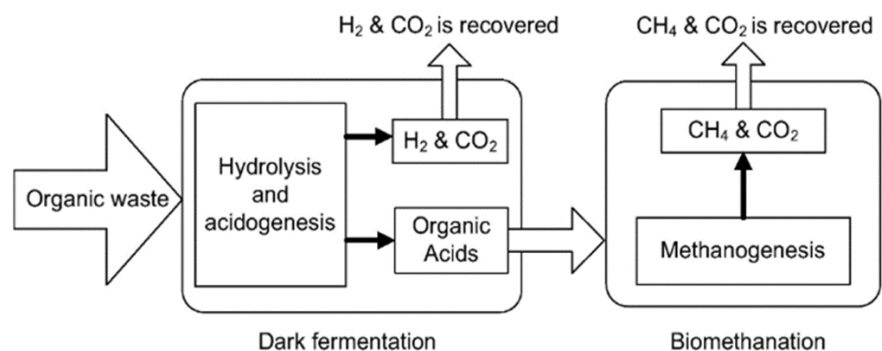

Category:	production of biohydrogen
Capacity:	scalable
Process phase:	FEED-study
Project period:	2019 - 2022
Project costs:	350 k Interreg subsidy
Contact:	www.biohydrogen.eu/kontakt/

Djewels-1



Realisation of a 20 MW Electrolyser in Delfzijl

Operated by Nouryon and Gasunie, it will provide 3,000 tons of green hydrogen per year, reducing CO₂ emissions by 27,000 tons per year. The produced hydrogen will be used for green methanol production for transport fuel at BioMCN. This plant also must validate the technical integrity and operating principles, stability and safety of a large-scale water electrolysis plant.

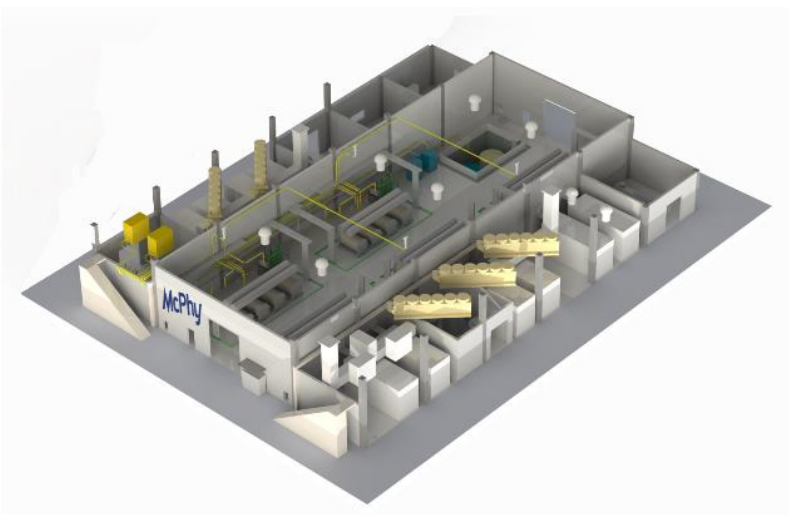

Category:	production of hydrogen
Capacity:	20 MW
Process phase:	FID in 2021
Project period:	2020 -
Project costs:	16 M subsidy
Contact:	www.gasunienewenergy.nl

Partners:

Nouryon

gasunie
crossing borders in energy

BioMCN

McPhy
Driving clean energy forward

Hinicio

DE NORA



Building a 250 MW Electrolysis Plant in Port of Rotterdam

The new factory will be able to produce 45,000 tons of green hydrogen annually. Because the hydrogen is produced from water with sustainable electricity, CO₂ emissions can decrease by 350,000 tons annually. BP will use the green hydrogen to desulphurise products and mobility projects. The H2-Fifty project will be in the so-called Conversion Park, a special site that the Port Authority is building on the Maasvlakte for electrolysers from various companies.



Category:	production of H ₂
Capacity:	250 MW
Process phase:	FEED-study
Project period:	2019 – 2022 (FID)
Project costs:	225 - 300 M
Contact:	hgj.regeer@portofrotterdam.com

Partners:



CCUS Infrastructure for Blue Hydrogen in Port of Rotterdam

Transfer of grey hydrogen production at the Botlek site of Air Products in the Port of Rotterdam into blue with CCUS into the North Sea bottom. The CO₂ will be transported through an offshore pipeline to a platform in the North Sea, approximately 20 km off the coast. From this platform, the CO₂ will be pumped in an empty gas field. The empty gas fields are situated in a sealed reservoir of porous sandstone, more than 3 km beneath the North Sea. It is expected that the system will be operational by 2024.

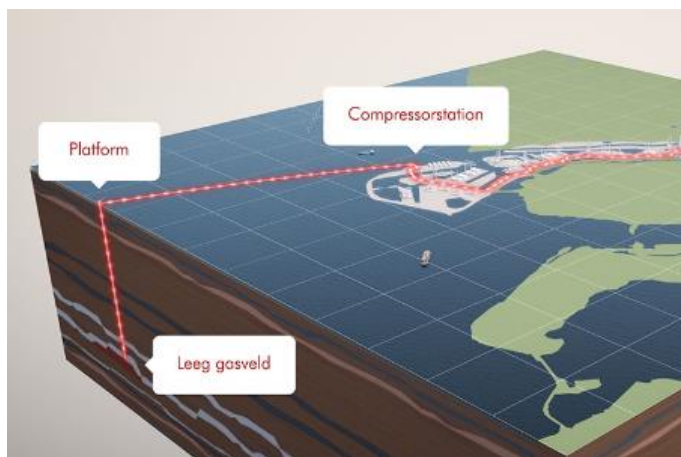

Category:	production of blue H ₂
Capacity:	2,5 million ton CO ₂ per year
Process phase:	FEED-study, FID in 2022
Project period:	2020 – 2024
Project costs:	2 B SDE++ / 120 M EU subsidy
Contact:	www.porthosco2.nl

Eemshydrogen

Building a 50 MW Hydrogen Plant for Westereems Wind Farm

The Eemshydrogen project demonstrates at scale (50MW) that electrolyzers can flexibly follow intermittent power production from a directly connected wind farm. The electrolyser supports development of a larger hydrogen infrastructure and targets CO₂-reduction in hard to abate industrial sectors. Depending on market conditions and regulations, the electrolysis capacity will be scaled up further.



Category:	production of green H ₂
Capacity:	50 MW
Process phase:	conceptual design
Project period:	COD in 2024
Contact:	ron.hoogsteen@rwe.com

Partners:



Hy4Am

Building a 10 MW Electrolyser at Hemweg Location

The goal is to supply approximately 200 kg / hour green hydrogen to mobility and industry in the Amsterdam region from 2024. The technical feasibility study has been successfully completed and the focus is currently on developing market demand and optimizing the business case. This plant is the first part of a fossil free hub (production, storage and distribution) for providing green electricity, heating and fuels for Amsterdam Metropool Region.



Category:	production of H ₂
Capacity:	10 MW, 200 kg/h
Process phase:	Feasibility-study finalised
Project period:	2018 – 2024, FID in 2022
Contact:	www.vattenfall.com/nl

Partners:





A Unique Approach for Industry to Achieve its Climate Targets with Low-CO₂ Hydrogen

Bringing together the full hydrogen value chain, to deliver 2,7 Mton of CO₂ emissions reductions for the Rotterdam industry by 2032. With two world-scale hydrogen plants, capturing over 95% of the CO₂ emissions. The unique process uses refinery fuel gas as its primary feedstock. The low-carbon hydrogen will have a purity of over 95%.

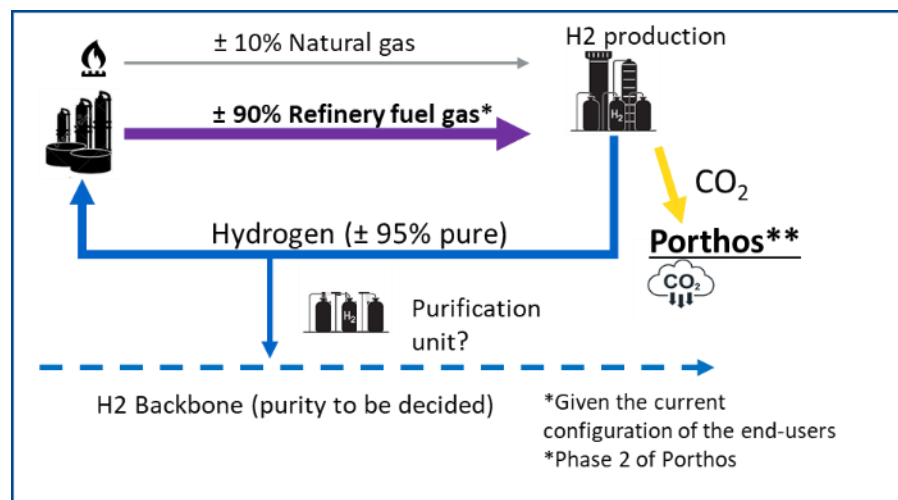

Category:	production of low-CO ₂ Hydrogen
Capacity:	2 plants of 750 MW
Process phase:	concept
Project period:	2020 - 2032
Project costs:	1-2 B investment
Contact:	kuipers@deltalinqs.nl



Creating a Green Hydrogen Ecosystem in North-Brabant

GreenH2UB is a 5-10 MW green hydrogen plant based on PEM electrolysis. Application and deployment in industry, mobility and built environment. The realization of the first GreenH2UB is set for the KBP in the Metropolis Region Eindhoven. The GreenH2UB will be connected directly to wind farm de Pals and solar farms. Finished the Concept Design and obtained a positive Feasibility Study.



Category:	production of green H ₂
Capacity:	5-10MW (330k-1m kg/y)
Process phase:	EED-study
Project period:	FID 2022, COD 2023
Project costs:	euro 12 Mio CAPEX
Contact:	www.greenh2ub.nl

Partners:



HEAVENN

H₂ Energy Applications in Valley Environments for Northern NL

The projects support focus on sectoral integration: the large-scale production of green hydrogen as a raw material for industry, the storage, transport and distribution of hydrogen and its application for energy supply for both industry and the built environment and in mobility.



Category:	production H ₂ in Energy Valley
Capacity:	30 subprojects
Process phase:	execution
Project period:	2020 - 2025
Project costs:	90 M
Contact:	New Energy Coalition

Partners:



Hydrogen Delta

Shift of the Largest Hydrogen Producer (580kta) and Consumer in the Benelux to a Sustainable Hydrogen Cluster.

The Hydrogen Delta Program aims to make industry more sustainable by phasing out gray hydrogen into blue hydrogen (CCS) and green hydrogen. In addition, efforts are made to use yellow hydrogen (import) and, when appropriate, orange hydrogen (nuclear). This by producing green hydrogen on a large scale, consuming it locally and importing and exporting it. The next step is to flesh out the kick-start of green hydrogen pilots.



Category:	production, distribution
Capacity:	>1 GW in projects
Process phase:	FEED-study
Project period:	2020 - 2030
Project costs:	>1 B
Contact:	www.smartdeltaresources.com

Partners:



GZI NEXT

A Second Life for the GZI Site in Emmen, with Hydrogen

Together they look at the possibilities of using the existing infrastructure for the generation of green gas through fermentation or gasification and for the generation of hydrogen. In 2020, province of Drenthe ordered 10 hydrogen busses and a 10 MW electrolyser is planned to feed them.



Category:	production, distribution
Capacity:	10 MW
Process phase:	FEED-study
Project period:	2020 -
Project costs:	1.6 M provincial subsidy
Contact:	www.gzinext.nl

Partners:



gasunie



ebn



provincie Drenthe



Bio Energy Netherlands

Wood Gasification with Production of Hydrogen and CO₂

The wood gasification plant in Amsterdam will extract hydrogen and CO₂ from the syngas, which can be used for transport fuels and in the chemical industry, amongst others. Developing and testing a gas upgrading system linked to a gasifier for production of green hydrogen.

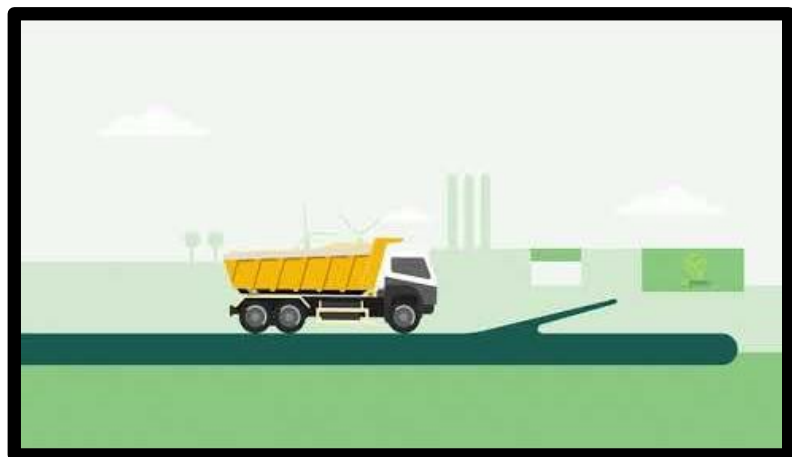

Category:	production
Capacity:	-
Process phase:	FEED-study
Project period:	2019 - 2021
Project costs:	TSE 500 k
Contact:	info@bioenergynetherlands.nl

Partners:



Bio Energy Netherlands

HYGEAR



Hydrogen Mill

Building a Windmill that Produces Hydrogen

The A 4 MW ENERCON windmill will be built in 2021 and a 2 MW electrolyser will be integrated in 2022. The goal of this project is to create synergy between the wind turbine, electrolyser and pipeline & storage. The demonstrator hybrid turbine will be built on the ECN test location in the Wieringermeer.



Category:	production, storage, distribution
Capacity:	2 MW
Process phase:	execution
Project period:	2021 - 2022
Project costs:	unknown
Contact:	adegoeij@hy-gro.nl

Partners:



PosHYdon

Hydrogen Production from North Sea Water on an Offshore Platform

A 1 MW electrolyser in a sea container on the platform, the Q13a, is very suitable for this. It is a fully electrified offshore platform. This electrification with green electricity saves 16.5 kt of CO₂ per year.



Category:	production of H ₂
Capacity:	1 MW
Process phase:	FEED-study
Project period:	2019 - 2021
Project costs:	unknown
Contact:	patrice.hijsterborg@neptuneenergy.com

Partners:

NEPTUNE
ENERGY

nexstep

TNO innovation
for life



H2ermes

Building a 100 MW Hydrogen Plant in Amsterdam for TaTa Steel

Deployment of hydrogen delivered by a 100 MW electrolysis plant to produce fuels and / or basic chemicals with the carbon monoxide (CO) and carbon dioxide (CO₂) in the residual gases from the steel production at TaTa Steel.

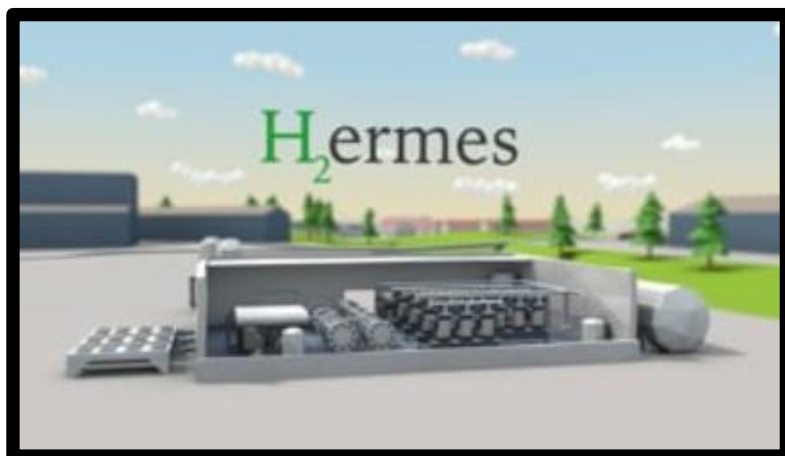

Category:	production
Capacity:	100 MW
Process phase:	FEED-study
Project period:	2019 -
Project costs:	150 M
Contact:	Floris.van.Foreest@portofamsterdam.com

Partners:



TATA STEEL

Nouryon



Molten Metal Methane Pyrolysis

Producing 'Turquoise' Hydrogen from Natural Gas

Methane pyrolysis produces hydrogen from natural gas with carbon (and not CO₂) as a valuable by-product. Affordable and commercially applicable within a few years. The applications are diverse. Think of additive for steel, filler in car tires, graphite, dye and soil conditioner.



Category:	production, knowledge
Capacity:	scalable
Process phase:	concept
Project period:	2019 - 2030
Project costs:	unknown
Contact:	willem.frens@tno.nl

Partners:



GH2

Producing Hydrogen by Gasification of Biomass in 'het Groene Hart'

The pilot plant of initially 1 kg H₂/day, the size of four parking spaces, is placed at Vermeulen Groep, a civil engineering company. Verge grass and wood waste is used for testing. The pilot will serve the design of a 500 kg H₂/day production plant using 10 ton/day biomass. On an annual basis that is <100 trucks. The gasifier of the production plant will be 2 MW thermal and co-produce 1 ton/day of biochar (so no ash), which is equal to 3 ton/day of CO₂ equivalents stored. The production of 500 kg hydrogen/day equals a 1.2 MW electrolyser which requires a 2x2.5 MW land-based windmills of 100 meters tall. The hydrogen obtained is partly used by Vermeulen Groep, who wants to make their business more sustainable.



Category:	production of H ₂
Capacity:	500 kg/day (=1.2MW)
Process phase:	pilotplant, demonstration
Project period:	2019 - 2022
Contact:	info@nettenergy.com



The Production of Green Hydrogen from a GW Windfarm in the North Sea

The objective is to generate 3 to 4 GW of wind energy for hydrogen production by 2030, and possibly 10 GW in 2040. Green hydrogen production of 800,000 tons, prevents around 7 megatons of CO₂ emissions per year. The final concept will be adopted in mid-2022 and then further developed towards an investment decision in 2024.



Category:	production of H ₂
Capacity:	3 - 4 GW wind – 0,8 Mt H ₂ /y
Process phase:	feasibility-study
Project period:	2020 - 2040
Project costs:	unknown
Contact:	https://www.north2.eu/

Partners:



HyNetherlands

Building a 100 MW Electrolyser in the Eemshaven

The factory will also have an important function for the balance in the electricity system. If the wind farms supply more electricity than is currently needed, it can be converted into hydrogen and stored. If necessary, the hydrogen can be converted back into electricity. ENGIE is now engaged in the preparatory activities for taking the final investment decision for the 100MW electrolyser at the end of 2021. Commissioning is scheduled for 2024.



Category:	production of hydrogen
Capacity:	100 MW to 1 GW
Process phase:	FEED-study
Project period:	FID 2021-2022
Project costs:	50 – 100 M
Contact:	www.engie.nl/over-ons/projecten/hynetherlands

gasunie
crossing borders in energy

ENGIE



GETEC
PARK.EMMEN



Empty Gas Fields Play a Role for Blue Hydrogen Production

The hydrogen gas can be produced with green energy from the (large) offshore wind farms that will be built in the coming decades. But even now hydrogen can be produced from natural gas. The released CO₂ can be captured and stored in the empty gas fields below the North Sea.

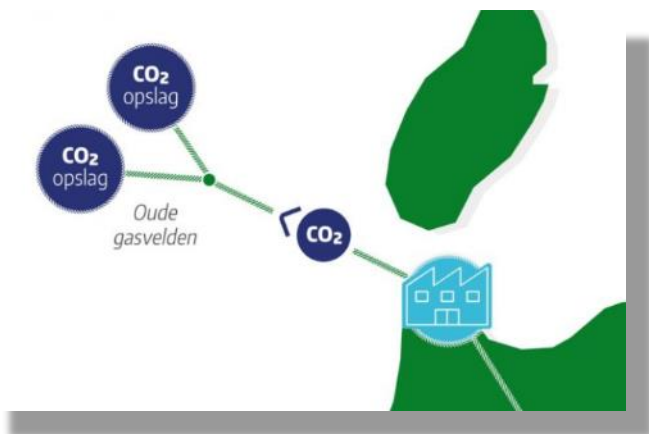

Category:	production of H ₂
Capacity:	0,2 Mt/year
Process phase:	Feasibility-study
Project period:	2020 - 2025
Project costs:	600 M euro
Contact:	Thijs Pennink, info@nhn.nl

Partners:



GldH2

A Hydrogen Value-Chain with Multi Purpose in Zutphen

Integral use of locally generated green hydrogen in Zutphen, among others for heating current homes in the city center, using existing gas pipelines and hydrogen-fired central heating boilers. In addition, also for industrial use and mobility, including heavy transport and public transport.



Category:	production and deployment
Capacity:	2 MW electrolyser
Process phase:	FEED-study
Project period:	2020 - 2023
Project costs:	400 k
Contact:	www.gldh2.nl

Partners o.a.:



PRIMAGAZ



Provincie Gelderland



Hydrogen Mill Sint Philipsland

To Use Profits to Benefit the Livability of the Community

The initiators of the windmill look for an alternative for the full electricity grid. The use of the national natural gas network for storage, distribution and deployment of their own production of hydrogen. Therefore, they hope to make the peninsula Sint Philipsland a hydrogen village.



Category:	production
Capacity:	1 windmill
Process phase:	feasibility-study
Project period:	2020 - 2022
Project costs:	225 k subsidy
Contact:	https://www.dorpsmolensintphilipsland.nl/

Partners o.a.:



Storage

Overview

FODEO

Flexible Storage, with Local Energy Exchange, of Sustainable Energy in Almere Oosterwold

The goal of FODEO is to contribute to optimizing the self-sufficiency of energy at the neighborhood level. This offers opportunities for a new market for local trading and storage of sustainable generated energy. Within the project we also look at organizational and legal issues. For example, we look at which amendments to legislation and regulations are necessary to make local energy communities possible.

Category:	storage
Capacity:	scalable
Process phase:	Feasibility-study
Project period:	2021 - 2025
Project costs:	450k TNO subsidy
Contact:	housen@fodeo.nl

Partners:

Battolyser

A Nickel-Iron Battery Combined with an Electrolyser

For the first time a short-term-energy-storage-system (battery) is combined with a long-term-energy-storage-system (electrolyser). When the battery is full, the surplus of energy produces hydrogen and oxygen for energy storage. This makes the battolyser flexible with respect to energy insertion. The device can be operational around the clock, either a surplus of energy is used to fill up storage capacity or energy is provided to consumers. A pilot development on the Magnum site in Zornhaven is being carried out.

Category:	storage
Capacity:	scalable
Process phase:	demonstration
Project period:	2019 - 2022
Project costs:	TSE + Vattenfalls subsidy
Contact:	www.battolyser.com

Partners:

Enowatts

Hydrogen Technology on Industrial Park de Kleefse Waard

Enowatts focuses on storage of excess wind energy in hydrogen, as well as local hydrogen applications at industrial park Industriepark Kleefse Waard (IPKW) in Aankeren, by means of systems modeling, development and testing.

Category:	storage
Capacity:	scalable
Process phase:	feasibility and FEED-studies
Project period:	2020 - 2022
Project costs:	700k (300k grant)
Contact:	enowatts@ten.nl

Partners:

Sinnewetterstof

A 1.4 MW Electrolyser Placed at a Solarpark for Netbalancing

Instead of reducing the generation at peak times, an electrolyser is used to convert electricity from the adjacent 50 MW Oosterschelde solar park into hydrogen. In this way a peak load in the grid becomes a prevented. The hydrogen produced is compressed to 300 bar and stored in tube trailers that can then be used later in hydrogen vehicles. The plant is expected to be operational by mid-2021.

Category:	storage, knowledge
Capacity:	1.4 MW
Process phase:	execution
Project period:	2019 - 2021
Project costs:	unknown
Contact:	ben.jubbens@psv.nl

Partners:

H2Fuel

A Technique for the Production, Storage and Release of H₂

The storage takes place under atmospheric conditions in a powder and the release takes place without added energy with very clean water. Hereby not only 100% of the hydrogen stored in the powder is released, but also the same amount of hydrogen from the water is harvested.

Category:	storage
Capacity:	scale up
Process phase:	FEED-study/proof of concept
Project period:	2019 -
Project costs:	unknown
Contact:	https://h2fuel.nl

Partners:

Cyrus Smith 2.0

Creating a Mobile 20 KW Electrolyser for Local Energy Storage

The fluctuating nature of renewable energy sources necessitates flexibility in use energy infrastructure. Thanks to the result of a technical solution project (the Cyrus Smith 1.0 project) of grid storage, local storage strategies have become available with corresponding grid interfaces. The current project aims to demonstrate full technical grid support (proof-of-principle).

Category:	storage, knowledge
Capacity:	20 KW
Process phase:	Feasibility-study (PwP)
Project period:	2020 - 2022
Project costs:	TSE 250k
Contact:	J.F. Janssen, HyMatters

Partners:

HyStock

A 1 MW P2G Installation with Large-scale Energy Storage

An installation has been set up to gain experience on a scale of 1 MW with the conversion of sustainably generated electricity from approximately 12,000 solar panels into hydrogen at Industriepark de Kleefse Waard. Large scale production of green hydrogen is necessary to achieve the 2050 climate goals. We believe that the better gas buffer can play an important role in this in the long term and can grow into an energy hub.

Category:	storage, production
Capacity:	1 MW
Process phase:	commissioning
Project period:	2019 - 2022
Project costs:	EU subsidy
Contact:	h@energyblock.com

Partners:



FODEO

Flexible Storage, with Local Energy Exchange, of Sustainable Energy in Almere Oosterwold

The goal of FODEO is to contribute to optimizing the self-sufficiency of energy at the neighborhood level. This offers opportunities for a new market for local trading and storage of sustainably generated energy. Within the project we also look at organizational and legal issues. For example, we look at which amendments to legislation and regulations are necessary to make local energy communities possible.

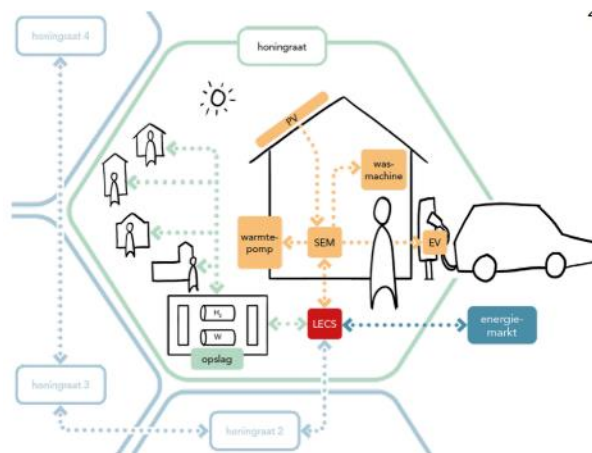

Category:	storage
Capacity:	scalable
Process phase:	Feasibility-study
Project period:	2021 – 2025
Project costs:	450k TKI subsidy
Contact:	leovanbemmel@villaville.nl

Partners:



Poinselot



A Nickel-iron Battery Combined with an Electrolyser

For the first time a short-term-energy-storage-system (battery) is combined with a long-term-energy-storage-system (electrolyser). When the battery is full, the surplus of energy produces hydrogen and oxygen for energy storage. This makes the battolyser flexible with respect to energy insertion. The device can be operational around the clock: either a surplus of energy is used to fill up storage capacity or energy is provided to consumers. A pilot development on the Magnum site in Eemshaven is being carried out.

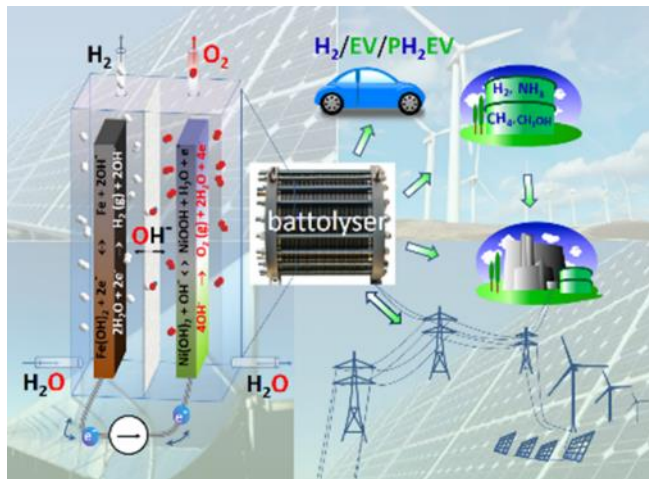

Category:	storage
Capacity:	scalable
Process phase:	demonstration
Project period:	2019 – 2022
Project costs:	TSE + Waddenfonds subsidy
Contact:	www.battolyser.com

Partners:



Knowledge grows



Enowatts

Hydrogen Technology on Industrial Park de Kleefse Waard

Enowatts focusses on storage of excess wind energy in hydrogen, as well as local hydrogen applications at industrial park Industriepark Kleefse Waard (IPKW) in Arnhem, by means of systems modelling, development and testing.

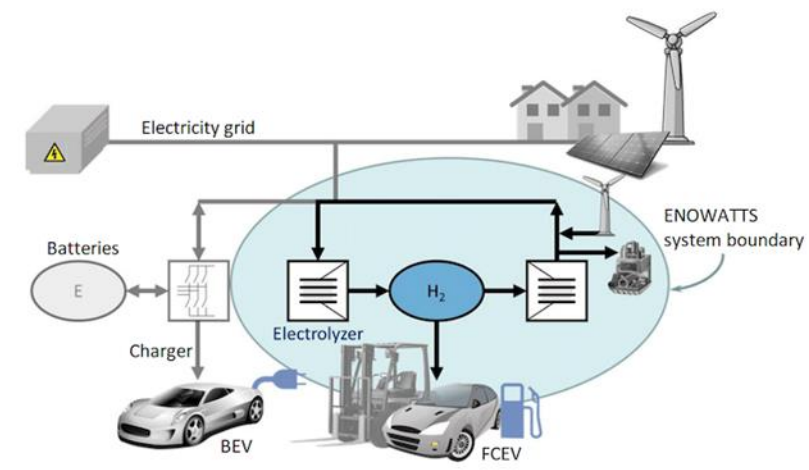

Category:	storage
Capacity:	scalable
Process phase:	feasibility and FEED-studies
Project period:	2020 - 2022
Project costs:	700k (300k grant)
Contact:	sustainable.energy@han.nl

Partners:



Sinnewetterstof

A 1.4 MW Electrolyser Placed at a Solarpark for Netbalancing

Instead of reducing the generation at peak times, an electrolyser is used to convert electricity from the adjacent 50 MW Oosterwolde solar park and water into hydrogen. In this way a peak load in the grid becomes is prevented. The hydrogen produced is compressed to 300 bar and stored in tube trailers that can then be used later in hydrogen vehicles. The plant is expected to be operational by mid-2021.



Category:	storage, knowledge
Capacity:	1.4 MW
Process phase:	execution
Project period:	2019 - 2021
Project costs:	unknown
Contact:	ben.tubben@qirion.nl

Partners:



GroenLeven
zonne-energie



H2Fuel

A Technique for the Production, Storage and Release of H₂

The storage takes place under atmospheric conditions in a powder and the release takes place without added energy with very clean water. Hereby not only 100% of the hydrogen stored in the powder is released, but also the same amount of hydrogen from the water is harvested.



Category:	storage
Capacity:	scale up
Process phase:	FEED-study/proof of concept
Project period:	2019 -
Project costs:	unknown
Contact:	https://h2-fuel.nl

Partners:



Cyrus Smith 2.0

Creating a Mobile 20 KW Electrolyser for Local Energy Storage

The fluctuating nature of renewable energy sources necessitates flexibility in our energy infrastructure. Thanks to the result of a technical validation project (the Cyrus Smith 1.0 project) of grid interaction, basic control strategies have become available with corresponding grid interface. The current project aims to demonstrate full technical grid support (proof-of-principle).



Picture: McPhy.com

Category:	storage, knowledge
Capacity:	20 KW
Process phase:	Feasibility-study (PoP)
Project period:	2020 - 2022
Project costs:	TSE 290k
Contact:	J.F. Janssen, Hymatters

Partners:



HyMatters

H2Consultancy

Making Fuelcell Systems



HyStock



A 1 MW P2G Installation with Large-scale Energy Storage

An installation has been set up to gain experience on a scale of 1 MW with the conversion of sustainably generated electricity from approximately 12,500 solar panels into hydrogen at Natuurgasbuffer Zuidwending. Large-scale production of green hydrogen is necessary to achieve the 2050 climate goals. We believe that the natural gas buffer can play an important role in this in the long term and can grow into an energy hub.



Category:	storage, production
Capacity:	1 MW
Process phase:	commissioning
Project period:	2018 - 2022
Project costs:	EU subsidy
Contact:	info@energystock.com

Partners:



Transportation

Overview

Backbone NL

Building a National Hydrogen Supply Chain in NL

Gasunie is building a national network that will connect future carbon-free hydrogen supply and demand. Five industrial clusters will be linked to each other, to foreign countries and to hydrogen storage facilities. This will be done mainly with existing infrastructure and partly with new infrastructure that has yet to be built. Current plans call for the first parts of the national backbone to be available in 2026. These are located in the north of the Netherlands, and in the Rotterdam area.

Category:	transportation
Capacity:	scalable
Process phase:	Feasibility-study
Project period:	2021 - 2030
Project costs:	1.5 billion €
Contact:	E.E.Lycklama.a.nijehof@gasunie.nl

Partners:

Hydrogen Oil

Liquid Organic Hydrogen Carriers as a Maritime Fuel

The fuel is produced through a process where Hydrogen and a liquid that we call Storage Oil are combined by applying heat and pressure in a patented process. Being a liquid, the Hydrogen Oil can easily be transported and refueled into a maritime vessel. Onboard of the vessel, the Hydrogen is released from the Hydrogen Oil by applying heat and pressure in the reverse process. When we release hydrogen, the liquid becomes Storage Oil which can be charged again for its next usage. This is tested in this pilot in IJzendoorn.

Category:	transport
Capacity:	scalable
Process phase:	execution
Project period:	2020 - 2022
Project costs:	1 M
Contact:	www.voyex.nl

Partners:

HyWay27

Using Existing Gas Network for the Transport of Hydrogen

From the point of view of cost-effectiveness it is important that the existing natural gas infrastructure is reused (in phases) where possible for the transport of hydrogen. How and under what conditions the existing natural gas network can be used is being investigated.

Category:	transport, distribution
Capacity:	125 Billion Nm³ n.g.u.
Process phase:	Feasibility-study - ready
Project period:	2020
Project costs:	unknown
Contact:	www.gasunie.nl

Partners:

Hydrogen Sensor Technology

Developing Better Sensors for Natural Gas / Hydrogen Mixtures

The project aims to develop a technology that allows the cost-effective and sufficiently accurate measurement of the composition of natural gas / hydrogen mixtures, wherein high concentrations of hydrogen are mixed (typically up to 90%). The HyDeploy (UK) project is a follow-up project, in which the developed sensor technology is put into a field test. In this project, up to 20% hydrogen is mixed in the natural gas. Duration until end 2022.

Category:	transportation
Process phase:	commissioning
Project period:	2018 - 2020
Project costs:	TSE 225k
Contact:	Hub Blokland, TNO

Partners:

Natural Gas Pipeline to H₂

YARA RECEIVES 4,000 tons of Green H₂ / Year from DOW Chemical

The hydrogen released by Dow crackers is used as a raw material for high-quality Yara products. This will result in an initial decrease in energy consumption of 0.15 PJ per year. In addition, it would reduce CO₂ emissions by 10,000 tons.

Category:	transportation
Capacity:	4,000 tons H ₂ /year
Process phase:	commissioning
Project period:	2017 - 2020
Project costs:	unknown
Contact:	evanoosteng@dow.com

Partners:



Backbone NL

Building a National Hydrogen Supply Chain in NL

Gasunie is building a national network that will connect future carbon-free hydrogen supply and demand. Five industrial clusters will be linked to each other, to foreign countries and to hydrogen storage facilities. This will be done mainly with existing infrastructure and partly with new infrastructure that has yet to be built. Current plans call for the first parts of the national backbone to be available in 2025. These are located in the north of the Netherlands, and in the Rotterdam area.

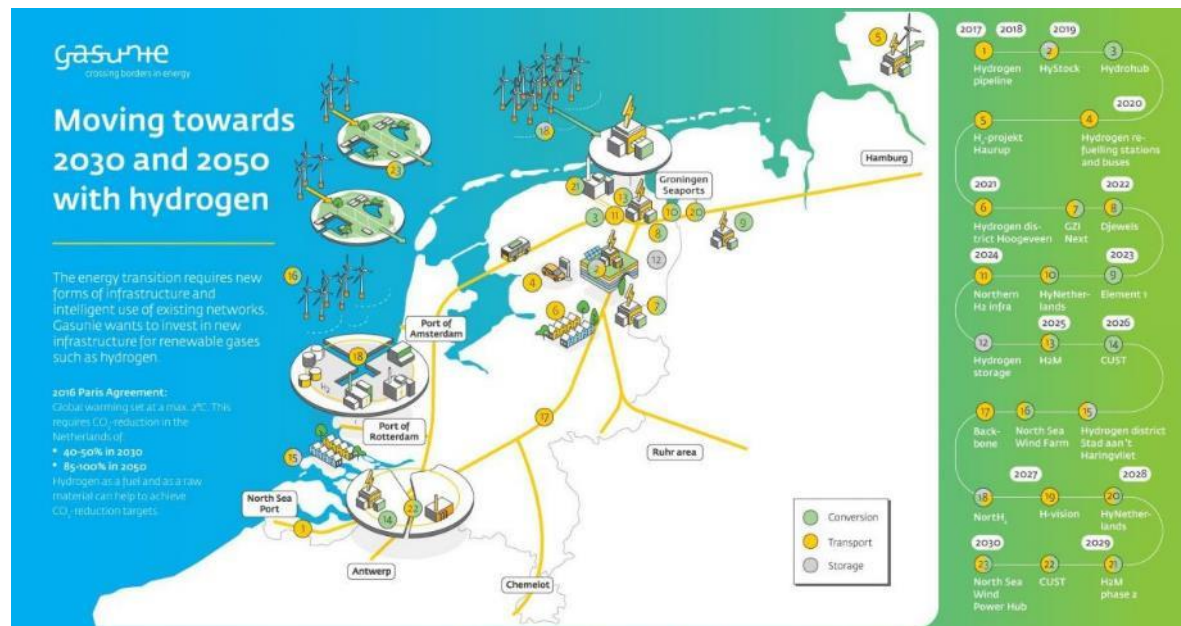

Category:	transportation
Capacity:	scalable
Process phase:	Feasibility-study
Project period:	2021 – 2030
Project costs:	1.5 billion €
Contact:	E.E.Lycklama.a.nijeholt@gasunie.nl



Hydrogen Oil

Liquid Organic Hydrogen Carriers as a Maritime Fuel

The fuel is produced through a process where Hydrogen and a liquid that we call Storage Oil are combined by applying heat and pressure in a patented process. Being a liquid, the Hydrogen Oil can easily be transported and refueled into a maritime vessel. Onboard of the vessel, the Hydrogen is released from the Hydrogen Oil by applying heat and pressure in the reverse process. When we release hydrogen, the liquid becomes Storage Oil which can be charged again for its next usage. This is tested in this pilot in IJzendoorn.

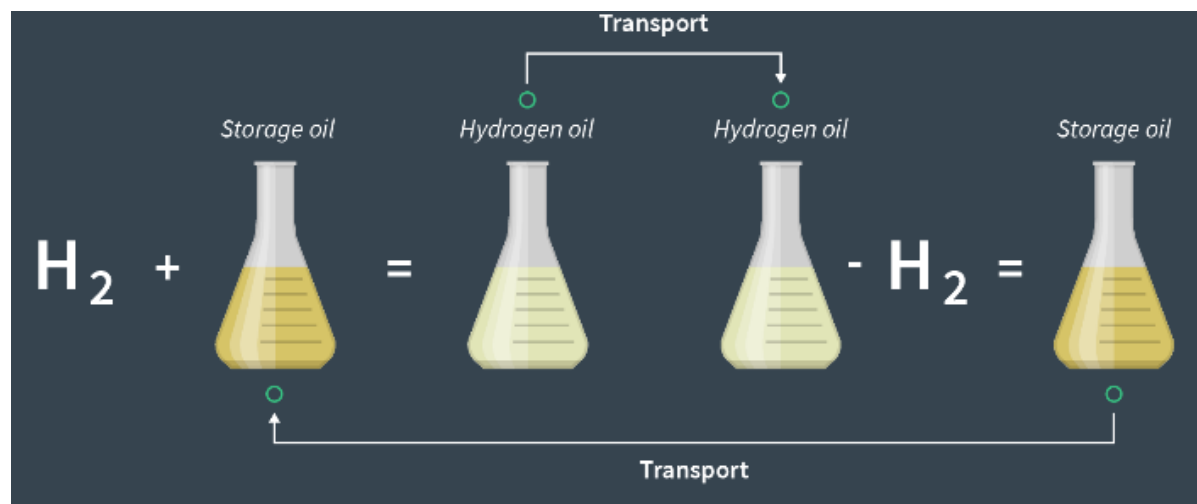

Category:	transport
Capacity:	scalable
Process phase:	execution
Project period:	2020 - 2022
Project costs:	1 M
Contact:	www.voyex.nl

Partners:



HyWay27

Using Existing Gas Network for the Transport of Hydrogen

From the point of view of cost-effectiveness it is important that the existing natural gas infrastructure is reused (in phases) where possible for the transport of hydrogen. How and under what conditions the existing natural gas network can be used is being investigated.



Category:	transport, distribution
Capacity:	125 Billion Nm ³ n.g.u.
Process phase:	Feasibility-study - ready
Project period:	2020
Project costs:	unknown
Contact:	www.gasunie.nl

Partners:



Ministerie van Economische Zaken
en Klimaat



Hydrogen Sensor Technology

Developing Better Sensors for Natural Gas / Hydrogen Mixtures

The project aims to develop a technology that allows the cost-effective and sufficiently accurate measurement of the composition of natural gas / hydrogen mixtures, wherein high concentrations of hydrogen are mixed (typically up to 90%). The HyDeploy (UK) project is a follow-up project, in which the developed sensor technology is put into a field test. In this project, up to 20% hydrogen is mixed in the natural gas. Duration until end 2022.



Category:	transportation
Process phase:	commissioning
Project period:	2018 – 2020
Project costs:	TSE 225k
Contact:	Huib Blokland, TNO

Partners:



Natural Gas Pipeline to H₂

YARA Receives 4,000 tons of Green H₂ / Year from DOW Chemical

The hydrogen released by Dow crackers is used as a raw material for high-quality Yara products. This will result in an initial decrease in energy consumption of 0.15 PJ per year. In addition, it would reduce CO₂ emissions by 10,000 tons.



Category:	transportation
Capacity:	4,000 tons H ₂ /year
Process phase:	commissioning
Project period:	2017 - 2020
Project costs:	unknown
Contact:	evanoosten@dow.com

Partners:



Knowledge grows



Distribution

Overview

H2Milk Run

Mobile Hydrogen Refuelling Station

Daily delivery of hydrogen via a small truck with a full functional HRS at multiple sites a day (a "Milk Run"). This initiative enables to start with fuel cell forklift trucks without the need to invest in infrastructure, in order to accelerate the use of hydrogen in logistics in a region. In spring 2022 the new GINAF truck will start to distribute hydrogen in the region of Ede.

Category:	distribution
Capacity:	1 truck
Process phase:	execution, demonstration
Project period:	2021 - 2024
Project costs:	1.25 M
Contact:	j.w.goesling@mobihy.com

Partners:

Hydrogen Street

Research into Possibilities for Reusing the Natural Gas Grid

The grid operators in the Green Village investigate the behavior of gas stations and their meters. They also research the necessary safety measures, such as new working methods and locks. This gas grid is therefore available as a testing site for other parties to do research.

Category:	distribution
Capacity:	scalable
Process phase:	commissioning
Project period:	2020 - 2025
Project costs:	unknown
Contact:	Elbert Huijzer, Allander

Partners:

NSWPH

North Sea Wind Power Hub; a Chain in Future Energy Supply

The Hub-and-Spoke concept consists of modular hubs in the North Sea connecting offshore wind farms with interconnectors to bordering North Sea countries and facilitates sector coupling through power-to-Hydrogen conversion.

Category:	distribution
Capacity:	10 > 30 GW
Process phase:	FEED-studies
Project period:	2020 -
Project costs:	unknown
Contact:	info@northseawindpowerhub.eu

Partners:



H2Milk Run

Mobile Hydrogen Refuelling Station

Daily delivery of hydrogen via a small truck with a full functional HRS at multiple sites a day (a "Milk Run"). This initiative enables to start with fuel cell forklift trucks without the need to invest in infrastructure, in order to accelerate the use of hydrogen in logistics in a region. In spring 2022 the new GINAF truck will start to distribute hydrogen in the region of Ede.



Category:	distribution
Capacity:	1 truck
Process phase:	execution, demonstration
Project period:	2021 - 2024
Project costs:	1.25 M
Contact:	j.w.gosseling@mobihiy.com

Partners:

GINAF



TOYOTA
MATERIAL HANDLING

**BOSCH
BETON**

bruil

**VETH
AUTOMOTIVE**

Bidfood
Waar professionals elkaar vinden

Air Liquide
Liquide Energie

Deloitte

MICHELIN
L'Expert du Pneumatique

TOYOTA

Microsoft



Hydrogen Street

Research into Possibilities for Reusing the Natural Gas Grid

The grid operators in the Green Village investigate the behavior of gas stations and their meters. They also research the necessary safety measures, such as new working methods and tools. This gas grid is therefore available as a testing site for other parties to do research.



Category:	distribution
Capacity:	scalable
Process phase:	commissioning
Project period:	2020 - 2025
Project costs:	unknown
Contact:	Elbert Huijzer, Alliander

Partners:



North Sea Wind Power Hub; a Chain in Future Energy Supply

The Hub-and-Spoke concept consists of modular hubs in the North Sea connecting offshore wind farms with interconnectors to bordering North Sea countries and facilitates sector coupling through power-to-Hydrogen conversion.



Category:	distribution
Capacity:	10 > 30 GW
Process phase:	FEED-studies
Project period:	2020 -
Project costs:	unknown
Contact:	info@northseawindpowerhub.eu

Partners:



Deployment: Energy Supply

Overview

High Hydrogen Retrofit Partnership

Hydrogen Gas Turbine Retrofit to Eliminate Carbon Emissions

To develop a cost-effective ultra-low emissions (sub 5ppm NOx and CO) combustion system retrofit for existing installed gas turbines in the output range of 1 MW to 300 MW. Fuel Flexibility and stable operation is required from 100% natural gas to 100% hydrogen.

Category:	deployment in energy supply
Capacity:	scalable
Process phase:	FEED-study
Project period:	2 nd phase 2021 - 2023
Project costs:	unknown
Contact:	www.enabioenergy.com/enabio-for-press

Partners:

Power2Power / Power2X

Decentralised Energy Management System Based on Hydrogen

The P2P/P2X system converts surplus wind electricity on site into hydrogen to match green energy offer and demand. The buffered hydrogen can be used for electricity, heat or (hydrogen) gas. Green energy becomes available 24 hours a day and large fluctuations in the grid are avoided.

Category:	deployment in energy supply
Capacity:	1 - 10 MW
Process phase:	FEED-study
Project period:	2020 -
Project costs:	unknown
Contact:	rob.vandenakker@nfsa.nl

Partners:

H2M: Hydrogen-to-Magnum

Conversion of 1,320 MW Magnum Natural Gas Power Plant at Eemshaven to Hydrogen including Storage of Hydrogen in Salt Caverns

Vattenfall, Equinor and Gasunie aim to develop large-scale production and off-take of low-carbon hydrogen in the Northern Netherlands, using ATR and CCS and production of CO₂-free flexible power. The H2M project can potentially reduce CO₂-emissions with 1.2 million tons per year if hydrogen is used for power production and in industry. The project can be realized in 6-7 years provided there is a concrete outlook on required financial support.

Category:	deployment in energy supply
Capacity:	3 x 443 MW
Process phase:	Pre-FEED ready
Project period:	2020 - 2030
Contact:	www.gasunie.nl

Partners:

H₂ Air Base Leeuwarden

Air Base Leeuwarden Focuses on Hydrogen and Biofuel

The feasibility study in 2020 showed potential to produce and store green hydrogen. First the 10 ha airport is estimated to be built in 2022. We want to use hydrogen for transport, in particular heavy transport and generating (emergency) power within the next 5 years; heating buildings within the next 10 years and making synthetic kerosene >10 years.

Category:	deployment in energy supply
Capacity:	18 MW solar power
Process phase:	FEED-study
Project period:	2021 - 2030
Project costs:	unknown
Contact:	koering.mink@pml.com

Partners:

Hysolar

The Production and Supply of Green Hydrogen in Nieuwegein

Hysolar opens a public hydrogen refueling station during the spring of 2021. The main hydrogen demand is generated by heavy duty machines (e.g. tractors, mowers, cones), trucks, buses, and further by passenger cars. The present fleet (yearly 2021) includes approx. 25 vehicles. Further, during 2022 a 2 MW electrolyser will be installed, which will be connected to a large solar park. Eventually, the project will produce 250 tons of green hydrogen per year.

Category:	deployment in energy supply
Capacity:	2 MW / 200 ton H ₂ / year
Process phase:	realisation
Project period:	2020 -
Project costs:	unknown
Contact:	www.hysolar.nl

Partners:

Zephyros

Development of a Maritime Hydrogen Hub in Den Helder

The aim is to demonstrate and validate green hydrogen as a maritime fuel on and around the Waddenzee. The project aims to realize a local solar park, an electrolyser, a pipeline from the electrolyser to an inland port and a public refueling facility, and a hydrogen-electric vessel for use by a port of maritime service providers and knowledge institutions. The electrolyser is used for flexibility services and congestion management to reduce the hydrogen price with renewables. The aim is to have the hub operational by the beginning of 2022.

Category:	deployment in energy supply
Capacity:	2 refilling stations/400 kg H ₂
Process phase:	FEED-study
Project period:	2019 - 2023
Project costs:	1.4 M DKT
Contact:	www.newenergycoalition.org

Partners:



High Hydrogen Retrofit Partnership

Hydrogen Gas Turbine Retrofit to Eliminate Carbon Emissions

To develop a cost effective ultralow emissions (sub 9ppm NOx and CO) combustion system retrofit for existing installed gas turbines in the output range of 1 MW to 300 MW. Fuel flexibility and stable operation is required from 100% natural gas to 100% hydrogen.

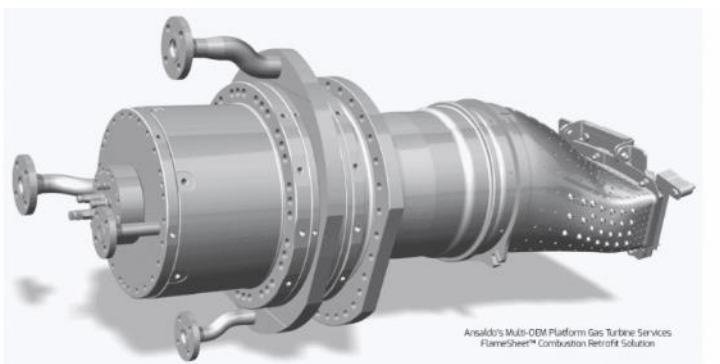

Category:	deployment in energy supply
Capacity:	scalable
Process phase:	FEED-study
Project period:	2 ^e phase 2021 - 2023
Project costs:	unknown
Contact:	www.ansaldoenergia.com/ansaldo-thomassen

Partners:



AkzoNobel



GETEC
PARK.EMMEN



VATTENFALL
Nouryon



Power2Power / Power2X

Decentralised Energy Management System Based on Hydrogen

The P2P/P2X system converts sun/wind electricity on site into hydrogen to match green energy offer and demand. The buffered hydrogen can be used for electricity, heat or (hydrogen) gas. Green energy becomes available 24 hours a day and large fluctuations in the grid are avoided.

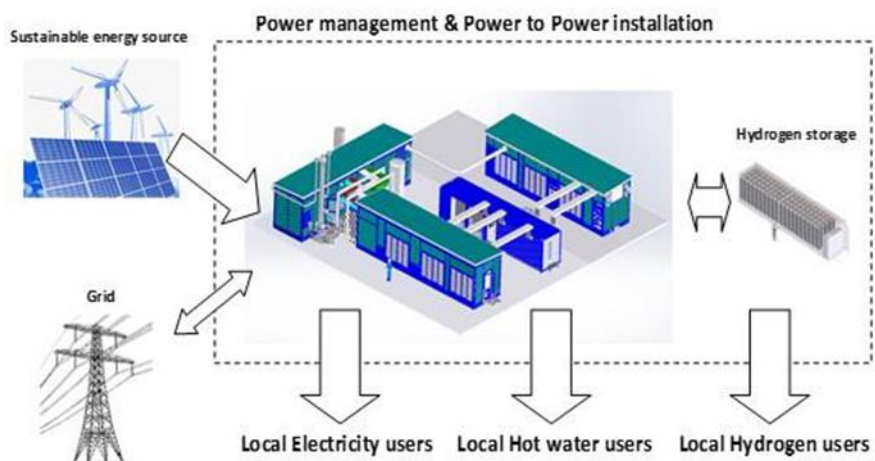

Category:	deployment in energy supply
Capacity:	1 – 10 MW
Process phase:	FEED-study
Project period:	2020 -
Project costs:	unknown
Contact:	rob.vandersluis@mtsa.nl

Partners:



H2M: Hydrogen-to-Magnum

Conversion of 1,320 MW Magnum Natural Gas Power Plant at Eemshaven to Hydrogen including Storage of Hydrogen in Salt Caverns

Vattenfall, Equinor and Gasunie aim to develop large-scale production and off-take of low-carbon hydrogen in the Northern Netherlands, using ATR and CCS and production of CO₂-free flexible power. The H2M project can potentially reduce CO₂-emissions with 1.2 million tons per year if hydrogen is used for power production and in industry. The project can be realized in 6-7 years provided there is a concrete outlook on required financial support.

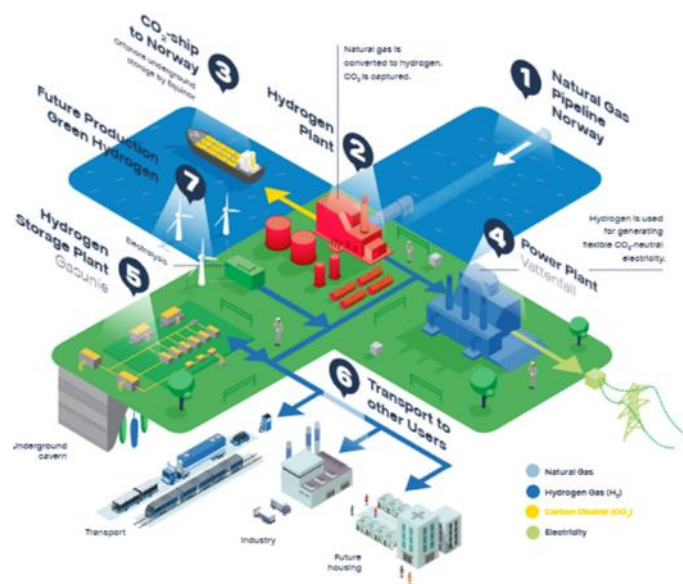

Category:	deployment in energy supply
Capacity:	3 x 440 MW
Process phase:	Pre-FEED ready
Project period:	2020 - 2030
Contact:	www.gasunienewenergy.nl

gasunie
new energy

VATTENFALL



equinor



H₂ Air Base Leeuwarden

Air Base Leeuwarden Focuses on Hydrogen and Biofuel

The feasibility-study in 2020 showed potential to produce and store green hydrogen. First the 10 ha. solarpark is estimated to be build in 2022. We want to use hydrogen for transport, in particular heavy transport and generating (emergency) power within the next 5 years, heating buildings within the next 10 years and making synthetic kerosene >10 years.



Category:	deployment in energy supply
Capacity:	18 MW solar power
Process phase:	FEED-study
Project period:	2021 - 2030
Project costs:	unknown
Contact:	koning.mindef@gmail.com

Partners:



Koninklijke Luchtmacht



Hysolar

The Production and Supply of Green Hydrogen in Nieuwegein

Hysolar opens a public hydrogen refueling station during the spring of 2021. The main hydrogen demand is generated by heavy duty machines (e.g. tractors, holders, cranes), trucks, buses, and further by passenger cars. The present fleet (early 2021) includes appr. 25 vehicles. Further, during 2022 a 2 MW electrolyser will be installed, which will be connected to a large solar park. Eventually, the project will produce 250 tons of green hydrogen per year.



Category:	deployment in energy supply
Capacity:	2 MW / 250 ton H ₂ / year
Process phase:	execution
Project period:	2020 -
Project costs:	unknown
Contact:	www.hysolar.nl

Partners:



Aannemingsbedrijf Jos Scholman



Zephyros

Development of a Maritime Hydrogen Hub in Den Helder

The aim is to demonstrate and stimulate green hydrogen as a maritime fuel on and around the Wadden Sea. The project aims to realize a local solar park, an electrolyser, a pipeline from the electrolyser to an inland port and a public refueling facility, and a hydrogen-electric vessel for use by a pool of maritime service providers and knowledge institutions. The electrolyser is used for flexibility services and congestion management to reduce the hydrogen price with revenues. The aim is to have the hub operational by the beginning of 2022.



Category:	deployment in energy supply
Capacity:	2 refilling stations/ 400 kg H ₂
Process phase:	FEED-study
Project period:	2019 - 2023
Project costs:	1.4 M DKTI
Contact:	www.newenergycoalition.org

Partners:



Deployment: Industrial

Overview



16

Hydrogen as a Fuel for Industrial Heating Processes

Development of Fuel Flexible Burner Concept

This projects aims to prepare energy-intensive industrial production processes (e.g. glass, food and ceramic sector) for a gradual transition from natural gas to hydrogen. The fuel flexible burner concept can handle any mix of natural gas and hydrogen.

Category:	industrial deployment of H ₂
Capacity:	100 kW – 200 MW
Process phase:	execution
Project period:	2020 - 2021
Project costs:	TSE 670 k
Contact:	Sander.Gersen@drw.com

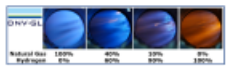

Partners: Industry consortium of 39 partners



16

NEDMAG on Hydrogen

Demonstration of H₂ Heating a 2 MW Oil Furnace

In this demonstration project the furnace of the industrial magnesium salt mining site of NEDMAG in Veendam will be fueled by varying natural gas/ hydrogen blends. To assure safe and reliable furnace operation, a Fuel Adaptive Control System is installed



Category:	industrial deployment of H ₂
Capacity:	2 MW
Process phase:	execution / commissioning
Project period:	2020 - 2021
Project costs:	unknown
Contact:	H.Hamstra@Nedmag.nl

Partners:



16



Hydrogen as a Fuel for Industrial Heating Processes

Development of Fuel Flexible Burner Concept

This project aims to prepare energy-intensive industrial production processes (e.g. glass, food and ceramic sector) for a gradual transition from natural gas to hydrogen. The fuel flexible burner concept can handle any mix of natural gas and hydrogen.

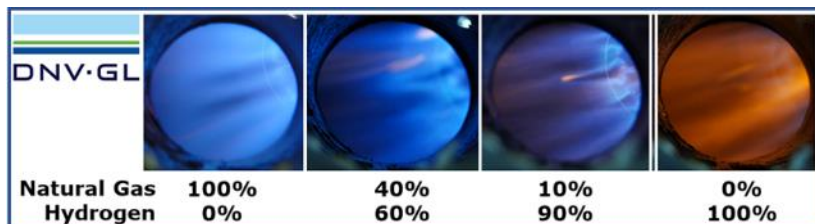

Category:	industrial deployment of H ₂
Capacity:	100 kW – 200 MW
Process phase:	execution
Project period:	2020 - 2021
Project costs:	TSE 670 k
Contact:	Sander.Gersen@dnv.com

Partners: Industry consortium of 35 partners



NEDMAG on Hydrogen

Demonstration of H₂ Heating a 2 MW Oil Furnace

In this demonstration project the furnace of the industrial magnesium salt mining site of NEDMAG in Veendam will be fueled by varying natural gas/ hydrogen blends. To assure safe and reliable furnace operation, a Fuel Adaptive Control System is installed



Category:	industrial deployment of H ₂
Capacity:	2 MW
Process phase:	execution / commissioning
Project period:	2020 - 2021
Project costs:	unknown
Contact:	H.Hamstra@Nedmag.nl

Partners:



Deployment: Mobility

Overview

This slide provides an overview of the presentation content, organized into a 3x4 grid of 12 smaller slide thumbnails. The thumbnails cover various topics related to hydrogen mobility, including project descriptions, technical details, and deployment strategies. A small circular logo with the letter 'm' is located in the bottom right corner of the slide frame.

Deployment: Mobility I

This slide is titled 'Deployment: Mobility I' and displays a grid of 20 smaller slide thumbnails. The thumbnails focus on deployment-related content, such as infrastructure requirements, pilot projects, and market analysis. A small circular logo with the letter 'm' is located in the bottom right corner of the slide frame.

Deployment: Mobility II

This slide is titled 'Deployment: Mobility II' and displays a grid of 16 smaller slide thumbnails. The thumbnails continue the deployment-related content, covering topics like policy support, financing, and operational challenges. A small circular logo with the letter 'm' is located in the bottom right corner of the slide frame.



Deployment: Mobility I

<h3>Overview</h3>	<h3>Deployment: Mobility II</h3>	<h3>HyTrucks</h3> <p>A concerted market approach for H2 port acceleration Port of Rotterdam - Port of Antwerp - Port of Duisburg</p> <p>HyTrucks aims to initiate the zero-emission heavy-duty transport vehicle value chain in the Port of Rotterdam with a focus on the Port of Antwerp and the Port of Duisburg. The HyTrucks initiative is based on 1,000 hydrogen-fueled trucks on the road as well as the corresponding low-carbon hydrogen production and refueling infrastructure by 2025.</p> <table border="1"> <tr><td>Category</td><td>Deployment in mobility</td></tr> <tr><td>Capacity</td><td>1,000 trucks, 20-25 refueling stations</td></tr> <tr><td>Process phase</td><td>FEED-study</td></tr> <tr><td>Project period</td><td>2020 - 2025</td></tr> <tr><td>Project code</td><td>790</td></tr> <tr><td>Contact</td><td>info@hytrucks.eu</td></tr> </table> <p>Partners: </p>	Category	Deployment in mobility	Capacity	1,000 trucks, 20-25 refueling stations	Process phase	FEED-study	Project period	2020 - 2025	Project code	790	Contact	info@hytrucks.eu	<h3>Green Planet</h3> <p>Building a Hydrogen Filling Station and Regional Transport Hub</p> <p>Green Planet is also called the "Hub of the Future". This is why we want to offer hydrogen for passenger cars at Green Planet in Pesse. To this end, we are working within the innovative TSO2020 project with many partners - including Cleanmax and Hyzon - who, like us, believe in hydrogen. In addition to refueling with hydrogen, we are also working with partners on a hydrogen transport hub in the northern Netherlands, a place where green hydrogen is compressed in relation to our data hub for hydrogen fuel.</p> <table border="1"> <tr><td>Category</td><td>Deployment in mobility</td></tr> <tr><td>Capacity</td><td>3 filling stations, 100 vehicles</td></tr> <tr><td>Process phase</td><td>commissioning</td></tr> <tr><td>Project period</td><td>2020 - 2022</td></tr> <tr><td>Project code</td><td>0100000</td></tr> <tr><td>Contact</td><td>info@greenplanet.nl</td></tr> </table> <p>Partners: </p>	Category	Deployment in mobility	Capacity	3 filling stations, 100 vehicles	Process phase	commissioning	Project period	2020 - 2022	Project code	0100000	Contact	info@greenplanet.nl	<h3>Hydrogen fuel cell sweeper</h3> <p>Sweeping of Inner Cities Without Emissions</p> <p>The fuel cell sweepers hydrogen and oxygen to generate energy to drive and power the machine, after which only a small amount of water vapor comes out of the exhaust. With the new sweeper we immediately introduce a hydrogen refueling infrastructure (H2 fuel). This was on the part of an expensive refueling system because the H2 just is flexible and offers the possibility to quickly and simply refuel for the empty hydrogen refueling tanks for a full hydrogen refueling system, refueling and refueling on board.</p> <table border="1"> <tr><td>Category</td><td>Deployment in mobility</td></tr> <tr><td>Capacity</td><td>10000 sweeper</td></tr> <tr><td>Process phase</td><td>evaluation, demonstration</td></tr> <tr><td>Project period</td><td>2019 - 2021</td></tr> <tr><td>Project code</td><td>0010000</td></tr> <tr><td>Contact</td><td>www.cleannet.nl</td></tr> </table> <p>Partners: </p>	Category	Deployment in mobility	Capacity	10000 sweeper	Process phase	evaluation, demonstration	Project period	2019 - 2021	Project code	0010000	Contact	www.cleannet.nl																								
Category	Deployment in mobility																																																															
Capacity	1,000 trucks, 20-25 refueling stations																																																															
Process phase	FEED-study																																																															
Project period	2020 - 2025																																																															
Project code	790																																																															
Contact	info@hytrucks.eu																																																															
Category	Deployment in mobility																																																															
Capacity	3 filling stations, 100 vehicles																																																															
Process phase	commissioning																																																															
Project period	2020 - 2022																																																															
Project code	0100000																																																															
Contact	info@greenplanet.nl																																																															
Category	Deployment in mobility																																																															
Capacity	10000 sweeper																																																															
Process phase	evaluation, demonstration																																																															
Project period	2019 - 2021																																																															
Project code	0010000																																																															
Contact	www.cleannet.nl																																																															
<h3>Hyzon Motors Europe</h3> <p>Building Heavy Duty Hydrogen Trucks in Winschoten</p> <p>Hyzon Motors Europe Technology and the European Hydrogen Hub will build heavy-duty hydrogen trucks in Winschoten that run on green hydrogen. The factory will initially make 100 trucks per year. Production will eventually be increased to 2,000 trucks annually. This means that the number of direct and indirect jobs generated by the factory will grow from the first month to a thousand jobs in the next years.</p> <table border="1"> <tr><td>Category</td><td>Deployment in mobility</td></tr> <tr><td>Capacity</td><td>2,000 heavy-duty trucks</td></tr> <tr><td>Process phase</td><td>evaluation</td></tr> <tr><td>Project period</td><td>2021 - 2025</td></tr> <tr><td>Project code</td><td>0100000</td></tr> <tr><td>Contact</td><td>info@hyzon.nl</td></tr> </table> <p>Partners: </p>	Category	Deployment in mobility	Capacity	2,000 heavy-duty trucks	Process phase	evaluation	Project period	2021 - 2025	Project code	0100000	Contact	info@hyzon.nl	<h3>WEVA</h3> <p>Building Hydrogen Electric Cargo Ship Antonie</p> <p>The use of hydrogen in inland shipping is still in its infancy. By developing a new ship like the Antonie, it will soon be possible to experiment further in practice with the production, storage and transport of hydrogen applications. In this way, hydrogen can develop as an important energy production system for inland vessels in addition to, for example, battery-electrically powered ships. The ship will be 135 meters long, 3,700 tons and will transport salt from the Heinoon factory in Delfzijl to the Eider in Rotterdam.</p> <table border="1"> <tr><td>Category</td><td>Deployment in mobility</td></tr> <tr><td>Capacity</td><td>1 cargo ship</td></tr> <tr><td>Process phase</td><td>FEED-study</td></tr> <tr><td>Project period</td><td>2021 - 2023</td></tr> <tr><td>Project code</td><td>8 M Ocean Deal subsidy</td></tr> <tr><td>Contact</td><td>www.rpi.nl</td></tr> </table> <p>Partners: </p>	Category	Deployment in mobility	Capacity	1 cargo ship	Process phase	FEED-study	Project period	2021 - 2023	Project code	8 M Ocean Deal subsidy	Contact	www.rpi.nl	<h3>ZEPS</h3> <p>Convert an Existing Passenger Ship into a Hypermodern, Hydrogen-powered Ship: From MIP3 Patris to ZEPS Patris</p> <p>The 2019 Zeeland Steam Passenger Ship will undergo a major renovation and conversion to a natural gas and hydrogen level. The existing diesel engines will be replaced. Accommodation of a 100% H2 fuel cell and a Li-Battery will form the basis of the energy supply. The tanking capacity, use and use energy will be used.</p> <table border="1"> <tr><td>Category</td><td>Deployment in mobility</td></tr> <tr><td>Capacity</td><td>1 passenger ship</td></tr> <tr><td>Process phase</td><td>FEED-study</td></tr> <tr><td>Project period</td><td>2021 - 2022</td></tr> <tr><td>Project code</td><td>0100000</td></tr> <tr><td>Contact</td><td>www.climatships.nl</td></tr> </table> <p>Partners: </p>	Category	Deployment in mobility	Capacity	1 passenger ship	Process phase	FEED-study	Project period	2021 - 2022	Project code	0100000	Contact	www.climatships.nl	<h3>GREEN SHIPPING WADDENZEE</h3> <p>World Heritage Site as an Inspiration for Sustainable Shipping with Hydrogen on the Wadden Sea</p> <p>The Green Shipping Waddenzee program aims to accelerate innovations in the field of CO2-neutral and low-carbon shipping for the Wadden Sea and to develop the associated port facilities and infrastructure. All this to support the ambition of a 90% CO2-reduction in 2030 for the Wadden Sea. There are 18 projects, of which 5 have already started, such as the conversion of the Eendracht and Neptune refueling of the ship in Oude Molen.</p> <table border="1"> <tr><td>Category</td><td>Deployment in mobility</td></tr> <tr><td>Capacity</td><td>10000000</td></tr> <tr><td>Process phase</td><td>feasibility study</td></tr> <tr><td>Project period</td><td>2020 - 2026</td></tr> <tr><td>Project code</td><td>20000</td></tr> <tr><td>Contact</td><td>www.greenshippingwaddenzee.nl</td></tr> </table> <p>Partners: </p>	Category	Deployment in mobility	Capacity	10000000	Process phase	feasibility study	Project period	2020 - 2026	Project code	20000	Contact	www.greenshippingwaddenzee.nl	<h3>H2Trac</h3> <p>Developing a Controlled Traffic Farming Tractor on Hydrogen</p> <p>H2Trac aims to build a tractor with a battery and a hydrogen fuel cell. The tractor will be used for controlled traffic farming (CTF) to help farmers with innovative ways to keep the soil healthy and improve yields. H2Trac wants to do this with tractors that are as clean as hydrogen and are also suitable for farming. The result: the same tractors are always used and the soil for the plants remains loose and cool. 5000 units of 7 tractors a year. The CO2 - 15 is built and is used for making the hydrogen system is planned for 2022.</p> <table border="1"> <tr><td>Category</td><td>Deployment in mobility</td></tr> <tr><td>Capacity</td><td>1 tractor</td></tr> <tr><td>Process phase</td><td>evaluation</td></tr> <tr><td>Project period</td><td>2021 - 2022</td></tr> <tr><td>Project code</td><td>0100000</td></tr> <tr><td>Contact</td><td>www.h2trac.com</td></tr> </table> <p>Partners: </p>	Category	Deployment in mobility	Capacity	1 tractor	Process phase	evaluation	Project period	2021 - 2022	Project code	0100000	Contact	www.h2trac.com
Category	Deployment in mobility																																																															
Capacity	2,000 heavy-duty trucks																																																															
Process phase	evaluation																																																															
Project period	2021 - 2025																																																															
Project code	0100000																																																															
Contact	info@hyzon.nl																																																															
Category	Deployment in mobility																																																															
Capacity	1 cargo ship																																																															
Process phase	FEED-study																																																															
Project period	2021 - 2023																																																															
Project code	8 M Ocean Deal subsidy																																																															
Contact	www.rpi.nl																																																															
Category	Deployment in mobility																																																															
Capacity	1 passenger ship																																																															
Process phase	FEED-study																																																															
Project period	2021 - 2022																																																															
Project code	0100000																																																															
Contact	www.climatships.nl																																																															
Category	Deployment in mobility																																																															
Capacity	10000000																																																															
Process phase	feasibility study																																																															
Project period	2020 - 2026																																																															
Project code	20000																																																															
Contact	www.greenshippingwaddenzee.nl																																																															
Category	Deployment in mobility																																																															
Capacity	1 tractor																																																															
Process phase	evaluation																																																															
Project period	2021 - 2022																																																															
Project code	0100000																																																															
Contact	www.h2trac.com																																																															
<h3>Energy Consortium Canal Zone</h3> <p>The Use of Hydrogen at Companies with Heavy Equipment</p> <p>Eight companies in the Canal Zone are working together to explore the sustainability of their operations and use hydrogen as the preferred solution. The Canal Zone Energy Consortium wants to test a hydrogen filling station ready by 2022. A location is also in the picture, the site of De Polder (the site of the Sandevinger in Venlo). The project is a part of the H2020 - Demonstration Technology - Decade, which investigates green hydrogen in real transport.</p> <table border="1"> <tr><td>Category</td><td>Deployment in mobility</td></tr> <tr><td>Capacity</td><td>filling station and vehicles</td></tr> <tr><td>Process phase</td><td>FEED-study</td></tr> <tr><td>Project period</td><td>ongoing since 2020</td></tr> <tr><td>Project code</td><td>0100000</td></tr> <tr><td>Contact</td><td>info@canalzone.nl</td></tr> </table> <p>Partners: </p>	Category	Deployment in mobility	Capacity	filling station and vehicles	Process phase	FEED-study	Project period	ongoing since 2020	Project code	0100000	Contact	info@canalzone.nl	<h3>Hydrogen Yard Tractor YT203-H2</h3> <p>Development and Demonstration of a Hydrogen Yard Tractor</p> <p>Testing of the fuel cell yard tractor started in October 2020 in the port of Rotterdam, where the vehicle is used in real operations to collect a wide range of data. The YT203-H2 operation covers all the operational requirements for different applications such as logistics, distribution and port gate for the global market. Demonstration is expected to start in 2022.</p> <table border="1"> <tr><td>Category</td><td>Deployment in mobility</td></tr> <tr><td>Capacity</td><td>1 Yard Tractor</td></tr> <tr><td>Process phase</td><td>start of construction in 2022</td></tr> <tr><td>Project period</td><td>2021 -</td></tr> <tr><td>Project code</td><td>supported by De Transport</td></tr> <tr><td>Contact</td><td>info@zepp.nl</td></tr> </table> <p>Partners: </p>	Category	Deployment in mobility	Capacity	1 Yard Tractor	Process phase	start of construction in 2022	Project period	2021 -	Project code	supported by De Transport	Contact	info@zepp.nl	<h3>ISHY</h3> <p>Implementation of Ship Hybridisation</p> <p>Part of the project is the development of a hydrogen fuel cell system suitable for medium-scale maritime applications. Zepp solutions will develop and produce this vehicle, which will be ready for implementation in 2022.</p> <table border="1"> <tr><td>Category</td><td>Deployment in mobility</td></tr> <tr><td>Capacity</td><td>2 ships in NL, 10000000</td></tr> <tr><td>Process phase</td><td>FEED-study</td></tr> <tr><td>Project period</td><td>2020 - 2023</td></tr> <tr><td>Project code</td><td>0100000</td></tr> <tr><td>Contact</td><td>www.ishy.nl</td></tr> </table> <p>Partners: </p>	Category	Deployment in mobility	Capacity	2 ships in NL, 10000000	Process phase	FEED-study	Project period	2020 - 2023	Project code	0100000	Contact	www.ishy.nl	<h3>H2Benelux</h3> <p>A real-life Trial Preparing Hydrogen Mobility in the BeNeLux</p> <p>The roll out of a basic network of hydrogen refueling stations in the BeNeLux through the deployment of 6 HRS and 80 FCV along the Benelux sections of the TONET Network. Countries, to establish the network of a sufficiently covered European wide network of HRS.</p> <table border="1"> <tr><td>Category</td><td>Deployment in mobility</td></tr> <tr><td>Capacity</td><td>10 HRS, 80 FCV</td></tr> <tr><td>Process phase</td><td>realisation</td></tr> <tr><td>Project period</td><td>2017 - 2021</td></tr> <tr><td>Project code</td><td>17.2 M CO2 - EATI support</td></tr> <tr><td>Contact</td><td>www.h2benelux.eu</td></tr> </table> <p>Partners: </p>	Category	Deployment in mobility	Capacity	10 HRS, 80 FCV	Process phase	realisation	Project period	2017 - 2021	Project code	17.2 M CO2 - EATI support	Contact	www.h2benelux.eu	<h3>Hydrogen Heavy Truck</h3> <p>Development of 50 Ton Bulk Carrier on Hydrogen</p> <p>Bosch's Berlin logistics department is increasingly faced with restrictions on construction projects within the environmental zones of large cities. The efficient delivery of concrete refueling units (crucial to services) developed by H2. Hydrogen fuel for the solution in this case.</p> <table border="1"> <tr><td>Category</td><td>Deployment in mobility</td></tr> <tr><td>Capacity</td><td>2 trucks and 10000000</td></tr> <tr><td>Process phase</td><td>FEED-study</td></tr> <tr><td>Project period</td><td>2020 - 2024</td></tr> <tr><td>Project code</td><td>0100000</td></tr> <tr><td>Contact</td><td>info@bosch.com</td></tr> </table> <p>Partners: </p>	Category	Deployment in mobility	Capacity	2 trucks and 10000000	Process phase	FEED-study	Project period	2020 - 2024	Project code	0100000	Contact	info@bosch.com
Category	Deployment in mobility																																																															
Capacity	filling station and vehicles																																																															
Process phase	FEED-study																																																															
Project period	ongoing since 2020																																																															
Project code	0100000																																																															
Contact	info@canalzone.nl																																																															
Category	Deployment in mobility																																																															
Capacity	1 Yard Tractor																																																															
Process phase	start of construction in 2022																																																															
Project period	2021 -																																																															
Project code	supported by De Transport																																																															
Contact	info@zepp.nl																																																															
Category	Deployment in mobility																																																															
Capacity	2 ships in NL, 10000000																																																															
Process phase	FEED-study																																																															
Project period	2020 - 2023																																																															
Project code	0100000																																																															
Contact	www.ishy.nl																																																															
Category	Deployment in mobility																																																															
Capacity	10 HRS, 80 FCV																																																															
Process phase	realisation																																																															
Project period	2017 - 2021																																																															
Project code	17.2 M CO2 - EATI support																																																															
Contact	www.h2benelux.eu																																																															
Category	Deployment in mobility																																																															
Capacity	2 trucks and 10000000																																																															
Process phase	FEED-study																																																															
Project period	2020 - 2024																																																															
Project code	0100000																																																															
Contact	info@bosch.com																																																															
<h3>H2RenT</h3> <p>Building 6 Hydrogen-powered Garbage Trucks</p> <p>The arena will be operating in different locations, so that municipalities and collection companies can become acquainted with hydrogen technology. A single aspect is that service companies are also involved in the demonstrative project.</p> <table border="1"> <tr><td>Category</td><td>Deployment in mobility</td></tr> <tr><td>Capacity</td><td>6 trucks</td></tr> <tr><td>Process phase</td><td>evaluation</td></tr> <tr><td>Project period</td><td>2019 -</td></tr> <tr><td>Project code</td><td>0100000</td></tr> <tr><td>Contact</td><td>info@h2rent.nl</td></tr> </table> <p>Partners: </p>	Category	Deployment in mobility	Capacity	6 trucks	Process phase	evaluation	Project period	2019 -	Project code	0100000	Contact	info@h2rent.nl	<h3>RH2INE</h3> <p>Rhine Hydrogen Integration Network of Excellence</p> <p>RH2INE is taking the first steps towards a demonstration network centered by developing the right conditions and infrastructure for the use of hydrogen for inland transport (shortly to be inland shipping). Inland shipping freight transportation by road and rail for first time. RH2INE will stimulate a targeted and efficient demand for hydrogen in the industry sector, aligned with a sustainable (hydrogen) value chain.</p> <table border="1"> <tr><td>Category</td><td>Deployment in mobility</td></tr> <tr><td>Capacity</td><td>10 ships and 10000000</td></tr> <tr><td>Process phase</td><td>FEED-study</td></tr> <tr><td>Project period</td><td>2021 - 2026</td></tr> <tr><td>Project code</td><td>1.200</td></tr> <tr><td>Contact</td><td>www.rh2ine.eu</td></tr> </table> <p>Partners: </p>	Category	Deployment in mobility	Capacity	10 ships and 10000000	Process phase	FEED-study	Project period	2021 - 2026	Project code	1.200	Contact	www.rh2ine.eu	<h3>DUWAAL</h3> <p>Development of a Green Hydrogen Economy in the Northwestern NL</p> <p>The realization of a first hydrogen gas station in Alkmaar, two hydrogen trucks, a hydrogen sweeper, the development of an integrated storage, transport and distribution system for hydrogen. It will be combined with a 4.5 MW hydrogen cell.</p> <table border="1"> <tr><td>Category</td><td>Deployment in mobility</td></tr> <tr><td>Capacity</td><td>2000</td></tr> <tr><td>Process phase</td><td>FEED-study</td></tr> <tr><td>Project period</td><td>2020 -</td></tr> <tr><td>Project code</td><td>0100000</td></tr> <tr><td>Contact</td><td>www.duwaal.nl</td></tr> </table> <p>Partners: </p>	Category	Deployment in mobility	Capacity	2000	Process phase	FEED-study	Project period	2020 -	Project code	0100000	Contact	www.duwaal.nl	<h3>H2SHIPS</h3> <p>System-Based Solutions for H2-Fueled Water Transport in NW Europe</p> <p>Development of a hydrogen supply chain for shipping (shortly to be inland shipping). A new hydrogen-powered port terminal will be built in Antwerpen. In Belgium, a H2 refueling system suitable for port use operation, will be developed and tested.</p> <table border="1"> <tr><td>Category</td><td>Deployment in mobility</td></tr> <tr><td>Capacity</td><td>1 port terminal</td></tr> <tr><td>Process phase</td><td>FEED-study</td></tr> <tr><td>Project period</td><td>2019 - 2022</td></tr> <tr><td>Project code</td><td>7.2 M CO2 - EATI support</td></tr> <tr><td>Contact</td><td>www.h2ships.eu</td></tr> </table> <p>Partners: </p>	Category	Deployment in mobility	Capacity	1 port terminal	Process phase	FEED-study	Project period	2019 - 2022	Project code	7.2 M CO2 - EATI support	Contact	www.h2ships.eu	<h3>REVIVE</h3> <p>Refuse Vehicle Innovation and Validation in Europe</p> <p>Integrating fuel cell powertrains into 12 vehicles and developing them at 8 sites across Europe. An additional task will explore the potential for "Waste-to-Water" business models where the fuel cell trucks are combined with more affordable green hydrogen sourced from waste plants.</p> <table border="1"> <tr><td>Category</td><td>Deployment in mobility</td></tr> <tr><td>Capacity</td><td>12 waste trucks</td></tr> <tr><td>Process phase</td><td>realisation</td></tr> <tr><td>Project period</td><td>2019 - 2021</td></tr> <tr><td>Project code</td><td>0.7 M CO2 - EATI support</td></tr> <tr><td>Contact</td><td>www.revive-project.eu</td></tr> </table> <p>Partners: </p>	Category	Deployment in mobility	Capacity	12 waste trucks	Process phase	realisation	Project period	2019 - 2021	Project code	0.7 M CO2 - EATI support	Contact	www.revive-project.eu
Category	Deployment in mobility																																																															
Capacity	6 trucks																																																															
Process phase	evaluation																																																															
Project period	2019 -																																																															
Project code	0100000																																																															
Contact	info@h2rent.nl																																																															
Category	Deployment in mobility																																																															
Capacity	10 ships and 10000000																																																															
Process phase	FEED-study																																																															
Project period	2021 - 2026																																																															
Project code	1.200																																																															
Contact	www.rh2ine.eu																																																															
Category	Deployment in mobility																																																															
Capacity	2000																																																															
Process phase	FEED-study																																																															
Project period	2020 -																																																															
Project code	0100000																																																															
Contact	www.duwaal.nl																																																															
Category	Deployment in mobility																																																															
Capacity	1 port terminal																																																															
Process phase	FEED-study																																																															
Project period	2019 - 2022																																																															
Project code	7.2 M CO2 - EATI support																																																															
Contact	www.h2ships.eu																																																															
Category	Deployment in mobility																																																															
Capacity	12 waste trucks																																																															
Process phase	realisation																																																															
Project period	2019 - 2021																																																															
Project code	0.7 M CO2 - EATI support																																																															
Contact	www.revive-project.eu																																																															



A concerted market approach for H2 growth acceleration Port of Rotterdam - Port of Antwerp - Port of Duisburg

HyTrucks aims to kickstart the zero-emission major heavy duty transportation vehicle value chain in the Port of Rotterdam with corridors to and in the Port of Antwerp and the Port of Duisburg. The HyTrucks ambition is have 1,000 hydrogen fuelled trucks on the road as well as the corresponding low carbon hydrogen production and refuelling infrastructure by 2025.

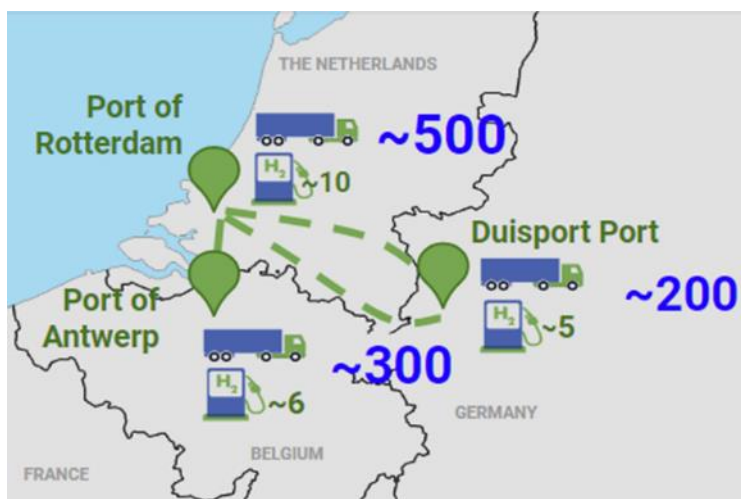

Category:	deployment in mobility
Capacity:	1,000 trucks, 20-25 refuelling stations
Process phase:	FEED-study
Project period:	2020 – 2025
Project costs:	TBD
Contact:	robert@gcnl.eu

Partners(NL):

Port of Rotterdam, Air Liquide, Air Products, VDL, Hyzon/Holthausen, Total Gas Mobility, Cummins/Hydrogenics, Vattenfall, Toyota Motor Europe, Vos Logistics, HN Post, Jongeneel Transport, Peter Appel, Simon Loos, Cornelissen Groep, Containerships, Waterstofnet



Green Planet



Building a Hydrogen Filling Station and Regional Transport Hub

Energy Hydrogen is also called the "fuel" of the future. That is why we want to offer hydrogen for passenger cars at Green Planet in Pesse. To this end, we are working within the innovative TSO2020 project with many partners - including Gasunie and TenneT - who, like us, believe in hydrogen. In addition to refueling with hydrogen, we are also working with partners on a hydrogen transport hub in the Northern Netherlands: a place where green hydrogen is compressed in trailers that can distribute the hydrogen further.



Category:	transport of H ₂ , distribution
Capacity:	1 filling station, hub
Process phase:	commissioning
Project period:	2020 – 2022
Project costs:	unknown
Contact:	https://greenplanet.nl/

Partners:



Hydrogen fuel cell sweeper

Sweeping of Inner Cities Without Emissions

The fuel cell uses hydrogen and oxygen to generate energy to drive and sweep the machine, after which only a small amount of water vapor comes out of the exhaust. With the new sweeper we immediately introduce a hydrogen exchange bottle system (H2 pod). This saves us the purchase of an expensive refueling system, because the H2 pod is flexible and offers the possibility to quickly and safely exchange the empty hydrogen exchange bottle for a full hydrogen exchange bottle, wherever and whenever we want.



Category:	deployment in mobility
Capacity:	500H2 sweeper
Process phase:	execution, demonstration
Project period:	2019 - 2021
Project costs:	DKTI-subsidy
Contact:	www.greenmachines.com

Partners:



CLEANMAT TRUCKS



Hyzon Motors Europe

Building Heavy Duty Hydrogen Trucks in Winschoten

Holthausen Clean Technology and the American Hyzon Motors will build heavy duty hydrogen trucks in Winschoten that run on green hydrogen. The factory will initially make 500 trucks per year. Production will eventually be increased to 2,000 trucks annually. This means that the number of direct and indirect jobs generated by the factory will grow from the first hundred to a thousand jobs in the next years.



Category:	deployment in mobility
Capacity:	2,000 trucks/year
Process phase:	execution
Project period:	2021 – 2025
Project costs:	unknown
Contact:	Carl@holthausen.nl

Partners:



WEVA

Building Hydrogen Electric Cargo Ship Antonie

The use of hydrogen in inland shipping is still in its infancy. By developing a new ship now that runs on green hydrogen, it will soon be possible to experiment further in practice with the production, storage and transport of hydrogen applications. In this way, hydrogen can develop as an important sustainable propulsion system for inland vessels in addition to, for example, battery-electrically powered ships. The ship will be 135 meters long, 3,700 tons and will transport salt from the Nouryon factory in Delfzijl to the Botlek in Rotterdam.



Category:	deployment in mobility
Capacity:	1 cargo ship
Process phase:	execution
Project period:	2021 – 2023
Project costs:	4 M Green Deal subsidy
Contact:	www.nprc.eu

Partners:



H. Lenten Scheepvaart



Nouryon



ZEPS

Convert an Existing Passenger Ship into a Hypermodern, Hydrogen-powered Ship: From MPS Patria to ZEPS Patria

The ZEPS (Zero Emission Passenger Ship) pilot project should guide shipping policy at a national and European level. The existing diesel engines will be replaced. A combination of a PEM-H₂ fuel cell and a Li-Battery pack form the basis of the energy supply. For back-up energy, solar and wind energy will be used.



Category:	deployment in mobility
Capacity:	1 passenger ship
Process phase:	FEED-study
Project period:	2020 – 2022
Contact:	www.climateships.eu



GREEN SHIPPING WADDENZEE

World Heritage Site as an Inspiration for Sustainable Shipping with Hydrogen on the Wadden Sea

The Green Shipping Waddenzee program aims to accelerate innovations in the field of CO₂-neutral and fossil-free shipping for the Wadden fleet and to develop the associated port facilities and infrastructure. All this to support the ambition of a 60% CO₂-reduction in 2030 for the Wadden region. There are 10 projects, of which 5 have already started, such as the conversion of the Ecolution and hydrogen refueling at the quay in Den Helder.



GREEN SHIPPING

Waddenzee

Category:	development in mobility
Capacity:	6 hydrogen projects
Process phase:	Feasibility-study
Project period:	2020 – 2024
Project costs:	25.8M
Contact:	https://greenshippingwaddenzee.nl/

Partners:



H2Trac

Developing a Controlled Traffic Farming Tractor on Hydrogen

H2Trac's vision is that land is farmers' best friend, something that must be nurtured. That's why H2Trac's mission is to help farmers with innovative ways to keep the soil healthy and improve yields. H2Trac wants to do this with machines that run on clean hydrogen and enable controlled traffic farming. As a result, the same tramlines are always used and the soil for the plants remains loose and vivid. With input of 7 farmers a new model, the EOX - 175 is build and is ready for testing; the hydrogen version is planned for 2022.



Category:	deployment in mobility
Capacity:	1 tractor
Process phase:	execution
Project period:	2020 - 2022
Project costs:	unknown
Contact:	www.h2trac.com

Partners:



Energy Consortium Canal Zone

The Use of Hydrogen at Companies with Heavy Equipment

Different companies in region Terneuzen want to make a leap in the sustainability of their companies and see hydrogen as the perfect solution. The Canal Zone Energy Consortium wants to have a hydrogen filling station ready by 2022. A location is also in the picture, the site of De Pooter Olie on the Beneluxweg in Terneuzen. This project is also part of WP2 of Zero Emission Transport Zeeland, which investigates green hydrogen in road transport.



Category:	deployment in mobility
Capacity:	filling station and vehicles
Process phase:	FEED-study
Project period:	ongoing as from 2020
Contact:	m.verschuren@h4a.nl



Hydrogen Yard Tractor YT203-H2

Development and Demonstration of a Hydrogen Yard Tractor

Testing of the fuel cell terminal tractor started in October 2020 in the port of Rotterdam, where the vehicle is deployed in daily operations to collect a wide range of data. The YT203-H2 specification covers all the operational requirements for different applications such as logistics, distribution and ports for the global market. Series production is expected to start in 2023.



Category:	deployment in mobility
Capacity:	1 Yard Tractor
Process phase:	proof of concept in 2020
Project period:	2018 -
Project costs:	supported by DKTI-program
Contact:	https://zepp.solutions/

Partners:



Implementation of Ship Hybridisation

Part of the project is the development of a hydrogen fuel cell system module suitable for medium scale maritime applications. Zepp.solutions will develop and produce this module, which will be ready for implementation in 2022.



Category:	deployment in mobility
Capacity:	2 pilots in NL (more EU-wide)
Process phase:	FEED-study
Project period:	2019 - 2023
Project costs:	9 M Interreg 2 Seas grant
Contact:	https://ishy.eu/



A real-life Trial Preparing Hydrogen Mobility in the BeNeLux

The roll out of a basic network of hydrogen refuelling stations in the BeNeLux through the deployment of 8 HRS and 80 FCEV along the BeNeLux sections of the TEN-T Network Corridors, to enable the creation of a sufficiently covered European wide network of HRS.



Category: deployment in mobility
 Capacity: 70 MPa HRS, FCEV
 Process phase: execution
 Project period: 2017 - 2021
 Project costs: 17.5 M CEF + DKTI transport
 Contact: michel.honselaar@waterstofnet.eu

Partners:



Rijkswaterstaat
Ministry of Infrastructure and the Environment



Hydrogen Heavy Truck

Development of 50 Ton Bulk Carrier on Hydrogen

Bosch's Beton logistics department is increasingly faced with restrictions on construction projects within the environmental zones of large cities. The efficient delivery of concrete retaining walls (photo) is seriously disrupted by this. Hydrogen can be the solution in this case.



Category:	deployment in mobility
Capacity:	2 trucks and a HRS[400kg/d]
Process phase:	FEED-study
Project period:	2020 - 2024
Project costs:	unknown
Contact:	brandjan@boschbeheer.com

Partners:



Building 6 Hydrogen-powered Garbage Trucks

The trucks will be operating in different locations, so that municipalities and collection companies can become acquainted with hydrogen technology. A unique aspect is that service companies are also involved in the demonstration project.



Category:	deployment in mobility
Capacity:	6 trucks
Process phase:	execution
Project period:	2019 -
Project costs:	unknown
Contact:	stefan.neis@waterstofnet.eu

Partners:



RH2INE



Rhine Hydrogen Integration Network of Excellence

RH2INE is taking the first step towards a zero-emission transport corridor by developing the right conditions and infrastructure for the use of hydrogen for the inland transport chain e.g., inland shipping, freight transportation by road and rail for the last mile. RH2INE will stimulate a targeted structural demand for hydrogen in the mobility sector, aligned with a sustainable hydrogen supply network.



Category:	deployment in mobility
Capacity:	10 ships and 3 filling stations
Process phase:	feasibility-study
Project period:	2020 – 2030
Project costs:	1.25 B
Contact:	www.rh2ine.eu



Partners: the Province of South Holland, the State of North Rhine-Westphalia, Ministry of Infrastructure and Water Management, Province of Gelderland, Port of Rotterdam Authority, Duisburg Port Authority RhineCargo, BCTN, EICB, Nouryon, Covestro, Air Products, Future Proof Shipping, HTS Group, NPRC, AirLiquide and Koedood.



DUWAAL

Development of a Green Hydrogen Economy in the Northwestern NL

The realization of a first hydrogen gas station in Alkmaar, two hydrogen trucks, a hydrogen sweeper, the development of an integrated storage, transport and distribution system for hydrogen. It will be combined with a 4.8 MW hydrogen mill.

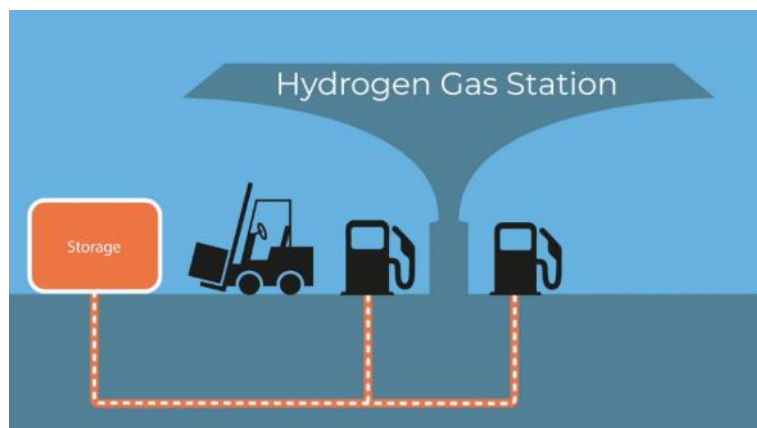

Category:	deployment in mobility
Capacity:	2 MW
Process phase:	FEED-study
Project period:	2020 -
Project costs:	DKTI 2 M
Contact:	adegoeij@hy-gro.nl

Partners:

HYGRO
enabling hydrogen from wind to wheel



H2SHIPS

System-Based Solutions for H₂-Fueled Water Transport in NW Europe

Development of a hydrogen supply chain for shipping (retrofit) inland vessels. A new hydrogen powered port vessel will be built in Amsterdam. In Belgium, a H₂ refueling system suitable for open sea operation, will be developed and tested.



Category:	deployment in mobility
Capacity:	1 port vessel
Process phase:	FEED-study
Project period:	2019 - 2022
Project costs:	7.2 M total EU project
Contact:	Jan.Egbertsen@portofamsterdam.com

Partners:



Refuse Vehicle Innovation and Validation in Europe

Integrating fuel cell powertrains into 15 vehicles and deploying them in 8 sites across Europe. An additional task will explore the potential for ‘Waste-to-Wheel’ business models where the fuel cell trucks are combined with more affordable green hydrogen sourced from waste plants.



Category:	deployment in mobility
Capacity:	15 waste trucks
Process phase:	execution
Project period:	2019 - 2021
Project costs:	8.7 M total EU project
Contact:	stefan.neis@waterstofnet.eu

Partners:



H₂ Filling Stations by OrangeGas



Designing and Building a Hydrogen Filling Point at Existing Gas Stations

At the locations it will be possible to refuel hydrogen with both 700 bar (passenger cars) and 350 bar (larger vehicles such as buses). Two hydrogen filling stations of Orangegas are in operation in The Hague and Amsterdam. In the next two years, subject to permits and subsidies, 5 small-scale stations in Drenthe and 5 fast-fill station cellars will be added.



Category:	deployment in mobility
Capacity:	350/700 Bar filling stations
Process phase:	execution
Project period:	2019 - 2023
Project costs:	DKTI + BENEFIC subsidy
Contact:	info@orangegas.nl

Partners:



H₂ Fuel Station in The Hague



Designing and building a Hydrogen Filling Point at Existing Gas Stations

After a long preparation, we can finally report that the installation of our 350/700 Bar hydrogen filling point is ready. At this point, anyone can help with testing by refueling.



Category:	deployment in mobility
Capacity:	350/700 Bar filling point
Process phase:	commissioning [in operation]
Project period:	2019 - 2022
Project costs:	unknown
Contact:	theodora.skordili@cenexgroup.nl

Partners:



SkyNRG

Green Hydrogen for Producing Sustainable Aviation Fuel (SAF)

Use of hydrogen from de Djewels-2 project to refine frying fat into sustainable kerosene and biopropane in the SkyNRG initiative in Delfzijl. From 2024, the plant will annually produce 100,000 tons of SAF, as well as 15,000 tons of bioLPG, as a byproduct. CO₂ reduction will be 270,000 tons a year.

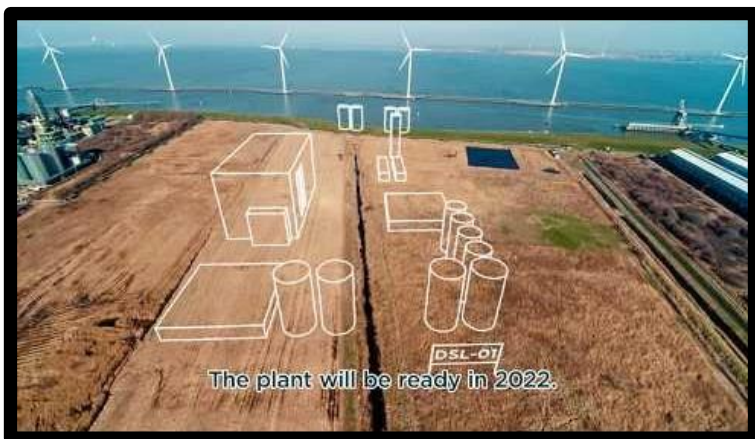

Category:	deployment in mobility
Capacity:	50 MW electrolyser capacity
Process phase:	FID in 2022
Project period:	2020 - 2024
Contact:	www.skynrg.com

Partners:



60 Fuel Cell Electric Buses



Towards Clean Public Transport with Hydrogen in the Netherlands

Demonstration of 60 hydrogen buses on Dutch public transportation. This is part of JIVE 2 subsidies and part of a greater European project. The hydrogen buses will run in the provinces of South Holland, Groningen, Drenthe and Gelderland.



Category:	deployment in mobility
Capacity:	60 buses
Process phase:	execution
Project period:	2018 - 2024
Project costs:	25 M total EU project
Contact:	marc.vandersteen@rebelgroup.com

Partners o.a. :



H2-SHARE

Hydrogen Solutions for Heavy-duty (27 tons) Transport in NW Europe.

For large heavy-duty vehicles which travel longer distances, electric trucks with a hydrogen fuel cell range extender are possible zero-emission solutions. In the EU, such vehicles are not yet commercially available but have enormous potential. 'H2-Share' aims to unlock this potential.



Category:	deployment in mobility
Capacity:	1 truck, 1 mobile filling station
Process phase:	commissioning
Project period:	2020 - 2023
Project costs:	1.7 M Interreg subsidy
Contact:	stefan.neis@waterstofnet.eu

Partners:

VDL, Wystrach GmbH, Rai Automotive NL, BREYTNER, Colruyt Group, Cure, DHL, e-mobil BW, Hydrogen Europe, Dutch Ministry of Infrastructure and Water Management, TNO, WaterstofNet. The city of Helmond and VIL



Hydrogen Train

Hydrogen Trains as a Sustainable Alternative for Diesel Trains

The province of Groningen wants to make rail transport in the north of the Netherlands more sustainable, which is currently still largely carried out by diesel trains. A pilot in 2020 with the Coradia iLint-hydrogen train, showed that the hydrogen train can be a fully-fledged alternative to the current diesel trains. The province has the ambition to run new trains on hydrogen from 2023.



Category:	deployment in mobility
Capacity:	1,000 km per filling
Process phase:	commissioning
Project period:	2020 - 2023
Contact:	https://www.hivemobility.nl/project/pilot-waterstoffrein/

Partners:

ProRail

 **arriva**
a DB company

 **ENGIE**

ALSTOM
• mobility by nature •

 **DEKRA**
On the safe side.



Incentive Package for 70 Additional Hydrogen Cars in the Arnhem Region

With a 50% discount on refueling and much more benefits, like hydrogen car introductory training, pick-up service and replacement transport. This promotion is intended for people who live and/or work a maximum of 30 kilometers from the center of Arnhem and is valid for 5 years after buying a hydrogen car. During the campaign 70 additional cars were sold to new owners.



Category:	deployment in mobility
Capacity:	70 additional cars
Process phase:	ended 24 july 2020
Project period:	2020
Project costs:	1 M
Contact:	www.h2-drive.nl



Energy Points

Refueling Stations with Hydrogen From and For the Future

Energy Points are modern hydrogen fueling stations with groundbreaking design. Holthausen is currently working on the realisation of 2 hydrogen filling stations in Groningen and Amsterdam. These 2 projects are being worked out and realised in collaboration with the municipalities.



Category:	deployment in mobility
Capacity:	2 refilling stations
Process phase:	execution
Project period:	2020-2022
Project costs:	DKTI-subsidy + 500 k A'dam
Contact:	www.energypoints.nl

Partners:



Hydrogen Region 2.0

A Hydrogen Filling Station in Breda and Helmond

The filling stations will supply green hydrogen to both passenger vehicles (700 bar) and heavy-duty vehicles (350 bar). In Breda, the waste service Breda can now fill its garbage trucks, and in 2022 passenger cars are welcome at the Mobility Hub. In Helmond the existing station is commercialized.



Category:	deployment in mobility
Capacity:	2 refilling stations
Process phase:	execution
Project period:	2020 - 2022
Project costs:	Interreg and DKTI-subsidy
Contact:	info@totalgasmobility.com

Partners:



Gemeente Breda



Developing a Hydrogen Filling Station in Roosendaal.

This project is localised near the Rotterdam-Antwerp hydrogen pipeline adjacent to the A17 highway. The next project of H2Point will be a hydrogen refilling station in Oosterhout. The project is subsidised by TDKI and BENEFIC.



Category:	deployment in mobility
Capacity:	2 refilling stations
Process phase:	execution
Project period:	Q1 2022 Roosendaal ready
Project costs:	1.5 M per station
Contact:	www.h2point.nl

Partners:



6 H₂ Filling Stations by Greenpoint Fuels

To Develop and Construct 6 Hydrogen Filling Stations in NL

Greenpoint Fuels currently has pending permit applications for 5 hydrogen filling stations. Creating a network of tapping points; the filling stations will be located in Zeewolde, Ede, Bleiswijk, Oude-Tonge, Haps and Sliedrecht. Three locations have already been licensed for hydrogen and 3 new locations will follow later this year. Talks with installation companies, governments and front runners are at an advanced stage.



Category:	deployment in mobility
Capacity:	6 H ₂ filling stations
Process phase:	execution
Project period:	2019 - 2023
Project costs:	unknown
Contact:	info@greenpointfuels.nl

Partners:



MEIJER & VAN EERDEN



68 Hydrogen Taxi's

Use of 68 Hydrogen Taxi's for Special Care (WMO) Transportation.

This is the first hydrogen taxi fleet in the Netherlands. Since 2019 35 Toyota Mirai's are driving in The Hague and 10 in Ede. In 2020 23 more hydrogen cars where added. *"The client requires us to be available 24/7 with our fleet. Due to the large range of the hydrogen car and the fast refueling, Noot Personenvervoer can offer this."*



Category:	deployment in mobility
Capacity:	68 H ₂ taxi's
Process phase:	commissioning
Project period:	2019 - 2022
Project costs:	unknown
Contact:	info@noot.nl

Partners:

NOOT
voor het hele koor



Den Haag

LOUWMAN
DEALERBEDRIJVEN



Hydrogen Ships Lauwersoog



Development of Ships Sailing on Green Hydrogen

The coalition WadDuurzaam has retrofitted the ship 'Ecolution' of Wubbo Ockels into hydrogen in 2021. After this first test ship, the sustainable port coalition in the province of Groningen wants to expand to fishing vessels, tour boats, the brown fleet and agricultural vehicles in the future.



Category:	deployment in mobility
Capacity:	scale up
Process phase:	execution
Project period:	2020 - 2030
Project costs:	1.2 M
Contact:	www.wadduurzaam.nl

Partners:



Speckless Water-based Inland Mobility (SWIM)



Hydrogen Watertaxi

Development of a water taxi running entirely on hydrogen. The first passengers are expected to be able to board in 2021. This project is developed within the zero-emission shipping program called THRUST. All hydrogen-related components are to be developed by zepp.solutions.



Category:	deployment in mobility
Capacity:	1 taxi boat
Process phase:	FEED-study/ execution
Project period:	2020 - 2023
Project costs:	confidential
Contact:	https://thrust.enviu.org/



Realization of Hydrogen Filling Stations along North-Sea Baltic Corridor

The project realizes a total of three Hydrogen filling stations including local hydrogen production and demand aggregation activities in Estonia, Latvia and the Netherlands. TOTAL Nederland has realized a Hydrogen Filling Station that facilitates refueling for both heavy duty vehicles (350 bar) and light duty vehicles (700 bar).

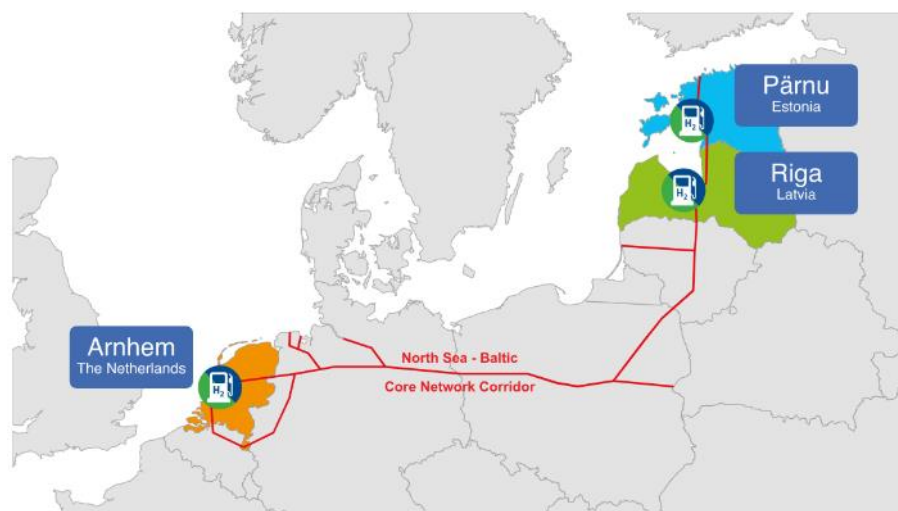

Category:	deployment in mobility
Capacity:	3 refilling stations
Process phase:	operational
Project period:	2014 - 2021
Project costs:	FCH-subsidy, co-funding
Contact:	https://www.h2nodes.eu/nl/

Partners:

Rīgas satiksme

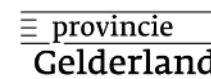

Deployment: Built Environment

<h3>Overview</h3>	<h3>Autonomous Hydrogen Heating System</h3> <p>Off Grid on Demand Hydrogen Production and Use in Homes</p> <p>The unique H₂ systems are connected to low voltage electricity for electrolysis as a way of production. The systems produce 100% emission CO₂ free hydrogen without any loss of efficiency. Ideally, the low voltage power needs to be provided by solar panels, wind or a generating electricity grid. An 'on-board' and 'on-demand' chilled water will be transformed into hydrogen and oxygen. These two elements combined are ideal for heating and generating energy in order to heat homes and tap water. The unique H₂O methodology creates maximum consumer independence from any supplier or utility company.</p> <p>Category: Deployment in built environment Capacity: 40 kW Process phase: system maturity, in 2022 on market Project period: 2019 - 2023 Project code: phase 1 H₂ - industry TSE Contact: www.120h.com</p>	<h3>Hydrogen Eeserwold</h3> <p>Development of a Business Park with a Hydrogen Energy Hub</p> <p>Hydrogen Eeserwold is being developed as a geographically central station north of Gronau. The nearby A52 and a central gas network provide the ideal infrastructure. The presence of the companies in the Eeserwold business park and the built environment provide opportunities. Research focus are possibilities to store and transport electricity from wind and sun from the surrounding area in gaseous form. A hydrogen filling station is planned at the water business park in 2021.</p> <p>Category: Deployment in built environment Capacity: 4 - 12000 development + filling station Process phase: Feasibility study Project period: 2020 - 2023 Project code: 8 to 45 Million Euro Contact: www.waterbusinesspark.nl</p>	<h3>Hydrogen District Wagenborgen</h3> <p>Connecting 40 Homes to the Local Hydrogen Network</p> <p>The hydrogen is used to heat the houses. The houses will receive a hybrid heat pump that can (or sustainably) generate electricity as much as possible. At said moments, a boiler working on hydrogen carbon can be used. The boiler will be installed and will receive solar panels and gas stored will be replaced by hydrogen tubes. The hydrogen that is needed is made by a burner in 'Stationen'. The gas is directly transported to the houses via existing gas pipes, and is fully use a new network to be built.</p> <p>Category: Deployment in built environment Capacity: 40 homes Process phase: execution Project period: 2021 - 2023 Project code: unknown Contact: ener@energypark.nl</p>	<h3>H2@Home</h3> <p>Research of in-house Installations with Hydrogen</p> <p>A consortium of companies, lead by Flanco and gplair, are doing research on in-house installations with hydrogen. They research a new reduce, generate and deliver of in-house piping systems for gas producing house connectivity. Slogan is also to find out which measurement technology systems are needed when using hydrogen instead of natural gas to heat residential houses and how to change their existing systems cover for natural gas.</p> <p>Category: knowledge, built environment Process phase: execution Project period: 2020 - 2023 Project code: 200k TSE subsidy Contact: Luisa.Moskat.gplair@flanco.nl Rien.Moore@flanco.nl Andreas.Klostermann@flanco.nl</p>
<h3>The Green Whale</h3> <p>Converting Existing Grid to a Local Produced Hydrogen Grid</p> <p>At the initiative of the Energy Coalition (Energy Club), 2200 homes conversion and 200 industrial for hydrogen will be converted from the natural gas and transfer them to hydrogen gas, produced on location. Our proposition is that converting a Dutch from natural gas to hydrogen gas will cost approximately 15,000 euros. This cost will be the same as the Groninger subsidie for Conversion CO₂, which subsidizes 23,000 euros and therefore with the club, but the costs remain considerably higher. In 2021 the feasibility study will be completed.</p> <p>Category: Deployment in built environment Capacity: 22 000 Process phase: Feasibility study Project period: 2020 - 2021 Project code: 2026 Contact: www.thegreenwhale.nl</p>	<h3>Innovahub</h3> <p>A Sustainable Power Station for the Built Environment in GO</p> <p>Innovahub meets the demand for electricity, heating and cooling from the residential district. The hub is supplied with energy generated by wind turbines and solar panels in the renewable surroundings. The innovation is the point for the storage and release of green hydrogen. Heat is released during the production of hydrogen in the Innovahub. This heat is stored, for future use during the cold seasons. The first installation will be located in 19,50 houses, construction will start this April. The project is completed in Q1 2022.</p> <p>Category: Deployment in built environment Capacity: 19,50 homes Process phase: execution Project period: 2021 - 2022 Project code: H2@Innovahub Contact: H2@Innovahub.nl</p>	<h3>HydroGEM</h3> <p>A Hydrogen Boiler without Incineration and Electricity for Homes</p> <p>The hydrogen boiler converts hydrogen gas into heat. A catalyst in the boiler creates a reaction between the recombined hydrogen and oxygen in the reactor chamber. The reaction activates an oxidation process without electricity or a flame. This reaction releases enough energy to heat an entire home. A system of heat exchangers provides hot tap water (DVG) for the central heating. The only by-product of the entire reaction is harmless water vapor. The future development is still ongoing, in collaboration with the University of Twente.</p> <p>Category: Deployment in built environment Capacity: 20 kW Process phase: execution Project period: 2021 - 2023 Project code: unknown Contact: H2@hydrogem.nl</p>	<h3>H2H.nu</h3> <p>Application of Hydrogen as an Energy Carrier in Wageningen</p> <p>Optimal use of Hydrogen gas as a replacement for natural gas in local housing schemes (renting) and industry (storage generation), by generating hydrogen at the location with an innovative electrolyser storage and using local solar farms for energy in 2021 concrete plans are made and collaborations with other initiatives, as in the city of Ede, is researched.</p> <p>Category: Deployment in built environment Capacity: residential area level Process phase: Feasibility study Project period: 2021 Project code: unknown Contact: H2@h2h.nl</p>	<h3>Retrofit Hydrogen Condensed Boiler</h3> <p>Towards the Introduction of H₂ in the Built Environment</p> <p>The new developed boiler is a retrofit of an existing domestic natural boiler in which several components, such as the burner and flame generating system are replaced. The boiler will be tested in a built house in 2020/2021.</p> <p>Category: Deployment in built environment Capacity: 30 kW Process phase: Feasibility study / POC Project period: 2020 - 2021 Project code: unknown Contact: Seider.Gertjan@dnv.com</p>
<h3>Power-To-Gas (P2G) Phase II</h3> <p>Power to Hydrogen for Residential Heating of Apartments in Rozenburg</p> <p>Decentralised integration of wind and solar energy via hydrogen from electrolysis for the heat supply of the built environment. The hydrogen is delivered by the regular natural gas pipelines to the boiler house of the apartment complex where the first hydrogen boiler gas tested.</p> <p>Category: Deployment in built environment Capacity: 3 residential houses Process phase: execution Project period: 2018 - 2020 Project code: unknown Contact: alfred.lindendorfer@stedin.nl</p>	<h3>Hydrogen Church</h3> <p>Heating the Monumental Eusebius Church with Hydrogen</p> <p>Using hydrogen from a sustainable source to heat a monumental church is new and offers an opportunity to reduce the carbon gas contribution of monuments. The possibilities and value will in a feasibility study and will receive a step-by-step permit is received, starting with heaters on 60% green hydrogen. You can then continue to give in heat all buildings up to 100% green hydrogen.</p> <p>Category: Deployment in built environment Capacity: several heaters Process phase: POC Project period: 2018 - 2023 Project code: unknown Contact: Dirk.Ockels@HyMatteurs.com</p>	<h3>Hydrogen Neighbourhood Hoogeveen</h3> <p>100 Newly Built Houses and 430 Existing Houses Connected to Hydrogen</p> <p>The newly built Allport-Doel residential area has been designated as a demonstrable project for the application of hydrogen in residential houses. The distribution plan will take into account the installation. Construction is expected to start in 2021. Other houses will be connected later.</p> <p>Category: Deployment in built environment Capacity: 530 houses Process phase: execution Project period: 2020 - 2023 Project code: H2p-0024 Contact: www.waia.nl/h2hoogeveen.nl</p>	<h3>Hydrogen City</h3> <p>Stad aan 't Haringvliet Switching to Green Hydrogen.</p> <p>Within the National Blue-Free Hydrogenworks Program, a pilot energy partners are working on a local hydrogen system that will enable the switch to hydrogen in 2023 under certain conditions. The hydrogen is to be used to heat the 600 houses in the village. The existing gas network can be used for the purposes, as its new network needs to be laid.</p> <p>Category: Deployment in built environment Capacity: 600 residential houses Process phase: Feasibility study Project period: 2017 - 2030 Project code: unknown Contact: info@stad-aan-t-haringvliet.nl</p>	<h3>Hydrogen Neighbourhood</h3> <p>Pilot Heating with Hydrogen in Neighbourhood Berkalsland, Lochem</p> <p>At Berkalsland there are relatively old, sometimes even monumental buildings. Residents are looking for sustainable alternative for natural gas. Since cooking cannot be done with hydrogen, solution would be the heat electric system. In winter 2020/2021 the pilot will be carried out.</p> <p>Category: Deployment in built environment Capacity: 40 - 15 residential houses Process phase: FEED study Project period: 2020 - 2021 Project code: unknown Contact: info@lochemh2.nl</p>



Autonomous Hydrogen Heating System

Off Grid on Demand Hydrogen Production and Use in Homes

The unique H₂O systems are powered by low voltage electricity for electrolysis as a way of production. The systems produce 100% emission CO₂ free oxy-hydrogen without any loss of transition return. Ideally, the low voltage power needs to be provided by solar panels, wind or a green/gray electricity grid. 'At location' and 'on demand' distilled water will be transformed into hydrogen and oxygen. These two elements combined are ideal for burning and generating energy in order to heat homes and tap water. The unique H₂O methodology creates maximum consumer independency from any supplier or utility company.

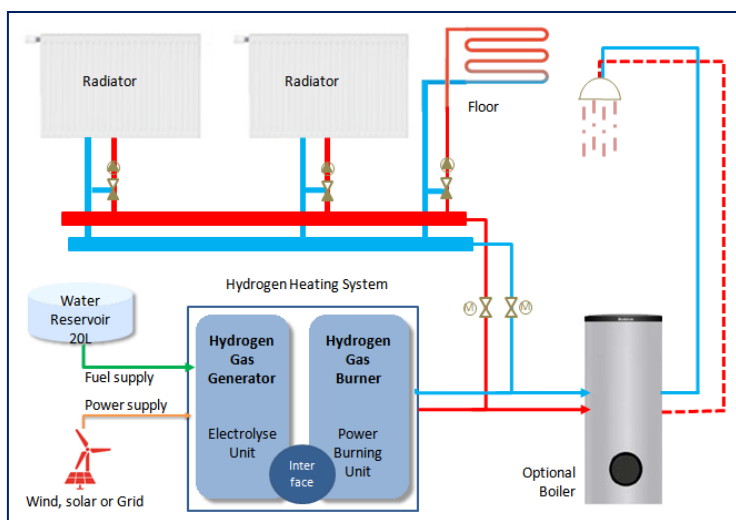

Category:	deployment in build environment
Capacity:	45 kW
Process phase:	system maturity, in 2022 on market
Project period:	2019 - 2022
Project costs:	phase 1 MIT- subsidy TSE
Contact:	www.h2osh.com

Partners:



Hydrogen Eeserwold

Development of a Business Park with a Hydrogen Energy Hub

Hydrogen Eeserwold is being developed at a geographically central location north of Steenwijk. The nearby A32 and a central gas network provide the ideal infrastructure. The presence of the companies in the Eeserwold business park and the built environment provide opportunities. Research topics are possibilities to store and transport electricity from wind and sun from the surrounding area in gaseous form. A hydrogen filling station is planned at the same business park for 2021.



Category:	deployment in build environment
Capacity:	4 - 30MW electrolyser + filling station
Process phase:	Feasibility-study
Project period:	2020 – 2023
Project costs:	9 to 45 Million Euros
Contact:	www.waterstofeeserwold.nl

Hydrogen District Wagenborgen

Connecting 40 Homes to the Local Hydrogen Network

The hydrogen is used to heat the houses. The homes will receive a hybrid heat pump that runs on sustainably generated electricity as much as possible. At cold moments, a boiler running on hydrogen switches on. The houses will be insulated and will receive solar panels and gas stoves will be replaced by induction hobs. The hydrogen that is needed is made by a farmer in Siddeburen. The gas is partly transported to the homes via existing gas pipes, and partly via a new network to be built.



Category:	deployment in build environment
Capacity:	40 homes
Process phase:	execution
Project period:	2021 – 2022
Project costs:	unknown
Contact:	www.enexisgroep.nl

Partners:



H2@Home

Research of In-house Installations with Hydrogen

A consortium of companies, lead by Flamco and gAvilar, are doing research on in-house installations with hydrogen. They research a new reducer, gasmeter and behavior of in-house piping systems for gas (including house connection). Target is also to find out which measurements/safety systems are needed when using hydrogen instead of natural gas to heat residential houses and how to change over existing systems used for natural gas.



Category:	knowledge, build environment
Process phase:	execution
Project period:	2020 - 2022
Project costs:	350k TSE subsidy
Contact:	Lianne Mostert, gAvilar Ben Mureau, Aalberts hydronic flow control

Partners:



The Green Whale



Converting Existing Grid to a Local Produced Hydrogen Grid

At the initiative of the Energy Coalition Graft-de Rijk, 2,200 home connections and 600 industrial farm buildings will be removed from the (natural) gas and transfer them to hydrogen gas, produced on location. Our proposition is that converting a home from natural gas to hydrogen gas will cost approximately 15,000 euros. This contrasts with the claims of the Economic Institute for Construction, EIB, which estimates 40,000 euros and therefore with the claim that the costs remain considerably higher. In 2021 the feasibility-study will be completed.



Category:	Deployment in build environment
Capacity:	30 MW
Process phase:	Feasibility-study
Project period:	2020 – 2021
Project costs:	225k
Contact:	www.degroenewalvis.com

Partners:

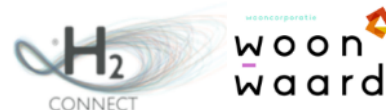

InnovaHub

A Sustainable Power Station for the Built Environment in GO

InnovaHub meets the demand for electricity, heating and cooling from the residential district. The Hub is supplied with energy generated by wind turbines and solar parks in the immediate surroundings. The InnovaHub is the point for the storage and release of green hydrogen. Heat is released during the production of hydrogen in the InnovaHub. This heat is stored, but there is also space for cold storage. The first installation will be linked to 15-20 homes; construction will start this April. We expect to complete this in Q1 2022.

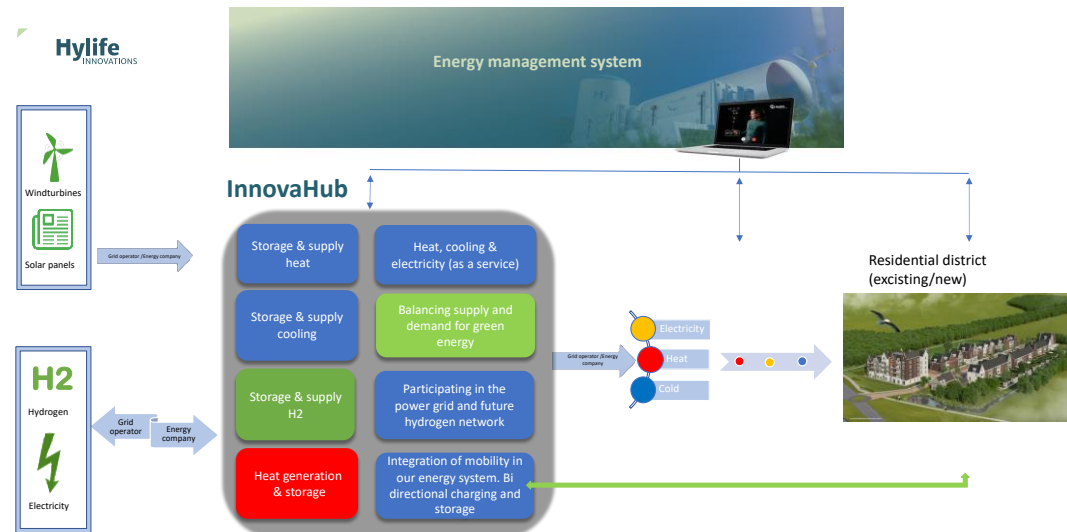

Category:	deployment in build environment
Capacity:	15-20 homes
Process phase:	execution
Project period:	2021 – 2022
Contact:	https://hylifeinnovations.nl/

H₂ydroGEM

A Hydrogen Boiler without Incineration and Electricity for Homes

The hydrogen boiler converts hydrogen gas into heat. A catalyst in the boiler creates a reaction between low-concentrated hydrogen and oxygen in the reaction channel. The catalyst activates an oxidation process without electricity or a flame. This reaction releases enough warmth to heat an entire home. A system of heat exchangers provides hot tap water (85°C) for the central heating. The only by-product of the entire reaction is harmless water vapour. The further development is still underway in collaboration with the University of Milan.



Category:	deployment in build environment
Capacity:	20 kW
Process phase:	execution
Project period:	2021 – 2023
Project costs:	unknown
Contact:	https://hylifeinnovations.nl/

Partners:



Application of Hydrogen as an Energy Carrier in Wageningen

Operated use of Hydrogen gas as replacement for natural gas in local housing schemes (heating) and industry (steam generation), by generating Hydrogen at the location with an innovative electrolyser concept and using local solar farms for energy. In 2021 concrete plans are made and collaboration with other initiatives, as in the city of Ede, is examined.

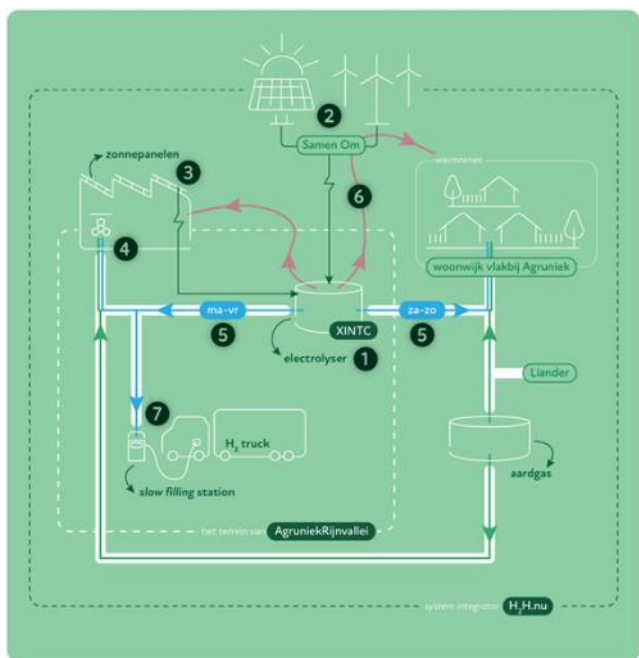

Category: deployment in built environment

Capacity: residential area level

Process phase: Feasibility-study

Project period: 2020 -

Project costs: unknown

Contact: <https://h2h.nu/>

Retrofit Hydrogen Condensed Boiler

Towards the Introduction of H₂ in the Built Environment

The new developed boiler is a retrofit of an existing domestic natural boiler in which several components, such as the burner and flame guarding system are replaced. The boiler will be tested in a field demo in 2020-2021.

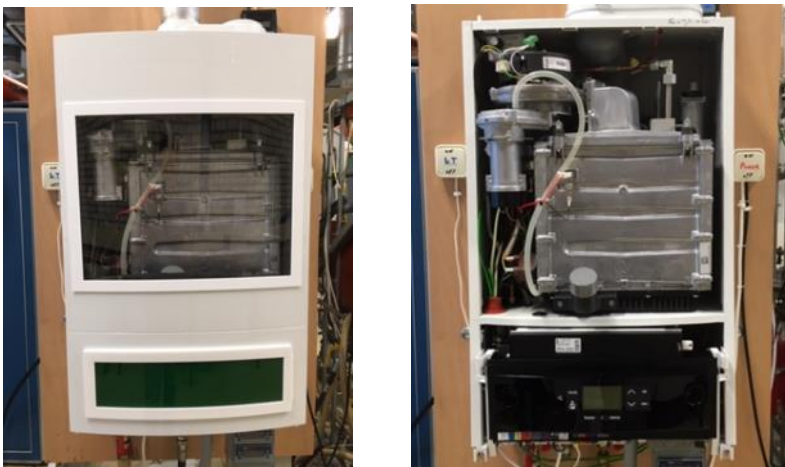

Category:	deployment in built environment
Capacity:	20 kW
Process phase:	Feasibility-study / POC
Project period:	2020 - 2021
Project costs:	unknown
Contact:	Sander.Gersen@dnv.com

Partners:



Power-To-Gas (P2G) Phase II

Power to Hydrogen for Residential Heating of Apartments in Rozenburg

Decentralized integration of wind and solar energy via hydrogen from electrolysis for the heat supply of the built environment. The hydrogen is delivered by the regular natural gas pipelines to the boiler house of the apartment complex where the first hydrogen boilers are tested.



Category:	deployment in built environment
Capacity:	3 residential houses
Process phase:	execution
Project period:	2018 - 2023
Project costs:	unknown
Contact:	albert.vandermolen@stedin.net

Partners:



Hydrogen Church

Heating the Monumental Eusebius Church with Hydrogen

Using hydrogen from a sustainable source to heat a monumental church is new and offers an opportunity to reduce the natural gas consumption of monuments. The possibilities were examined in a feasibility study. And with success! A step-by-step route is proposed, starting with heaters on 50% green hydrogen. You can then continue to grow to have all heaters burn on 100% green hydrogen.



Category:	deployment in build environment
Capacity:	several heaters
Process phase:	FID
Project period:	2019 - 2023
Project costs:	unknown
Contact:	Dick.Breteler@HyMatters.com

Partners:



Hydrogen Neighbourhood Hoogeveen

100 Newly Built Houses and 430 Existing Houses Connected to Hydrogen

The newly built Nijstad-Oost residential area has been designated as a demonstration project for the application of hydrogen in newly-built houses. The destination plan will soon be brought into execution. Construction is expected to start in 2021. Other houses will be connected later.



Category:	deployment in built environment
Capacity:	530 houses
Process phase:	execution
Project period:	2020 - 2023
Project costs:	TSE 400 k
Contact:	www.waterstofhoogeveen.nl

Partners:

Stork Nederland BV, Nederlandse Gasunie NV, GasTerra BV, Nederlandse Aardolie Maatschappij N.V., Bekaert Combustion Technology BV, N-TRA BV (onderdeel netwerkbedrijf RENDO), Instituut Fysieke Veiligheid (IFV), Cogas Innovatie & Ontwikkeling B.V, Nedstack B., JP-Energiesystemen B.V, Hanze University of Applied Sciences, Provincie Drenthe, Stichting New Energy, Visser & Smit Hanab Distributie B.V, Green Planet Pesse B.V, DNV-GL Netherlands B.V., Arcadis Nederland B.V, BAM Infra Energie & Water B.V, Haskoning BV, DHV Nederland B.V, Enexis Netbeheer B.V en Liander N.V en gemeente Hoogeveen.



Hydrogen City

Stad aan 't Haringvliet Switching to Green Hydrogen.



Within the Natural Gas-Free Neighborhoods Program, a great many partners are working on a local hydrogen system that will enable the switch to hydrogen in 2025 under certain conditions. The hydrogen is to be used to heat the 600 houses in the village. The existing gas network can be used for the purpose, so no new network needs to be laid.



Category:	deployment in built environment
Capacity:	600 residential houses
Process phase:	Feed-study
Project period:	2017 - 2050
Project costs:	unknown
Contact:	stadaardgasvrij@gmail.com

Partners:



Hydrogen Neighbourhood

Pilot Heating with Hydrogen in Neighbourhood Berkeloord, Lochem

At Berkeloord there are relatively old, sometimes even monumental buildings. Residents are looking for sustainable alternatives for natural gas. Since cooking cannot be done with hydrogen; induction would be the most obvious option. In winter 2020/2021 the pilot will be carried out.



Category:	deployment in built environment
Capacity:	10 - 15 residential houses
Process phase:	FEED-study
Project period:	2020 - 2021
Project costs:	unknown
Contact:	info@lochemenergie.net

Partners:



Knowledge

Overview

The Overview slide displays a grid of 12 small thumbnail images, each representing a different project component or milestone. The thumbnails are arranged in a 3x4 grid. The first thumbnail in the top-left corner is highlighted with a red border and contains the text 'Overview of the Hydrogen Project 2020-2025'. The other thumbnails show various charts, diagrams, and logos related to the project.

Knowledge I

The Knowledge I slide displays a grid of 12 small thumbnail images, each representing a different project component or milestone. The thumbnails are arranged in a 3x4 grid. The first thumbnail in the top-left corner is highlighted with a red border and contains the text 'Knowledge I'. The other thumbnails show various charts, diagrams, and logos related to the project.

Knowledge II

The Knowledge II slide displays a grid of 12 small thumbnail images, each representing a different project component or milestone. The thumbnails are arranged in a 3x4 grid. The first thumbnail in the top-left corner is highlighted with a red border and contains the text 'Knowledge II'. The other thumbnails show various charts, diagrams, and logos related to the project.



Knowledge I

Overview

Knowledge II

WaterstofLab

HydrogenLab for the Built Environment

The HydrogenLab brings together relevant parties and knowledge to conduct an open dialogue about the following question: "How do we ensure clarity about the role of hydrogen in the energy mix for the built environment?" The common challenge is to make the built environment CO₂ neutral, at the lowest possible social costs and the greatest possible added value. This requires choices that are made here and now. Anyone who can and wants to contribute to more nuance in the debate about hydrogen in the built environment, and is open to a constructive dialogue, is more than welcome to participate in this (online) hydrogen community.

Waterstof LAB

Partners (initiators):

Category:	knowledge, societal acceptance
Capacity:	70+ members
Process phase:	open for contribution
Project period:	2020 - 2021
Contact:	https://waterstoflab.nl

Zero Emissie Transport Zeeland

The Use of Hydrogen in Transport

The project will encourage companies to introduce Zero Emission Transport into their own business cases. In one of the working packages the role for green hydrogen in heavy transport will be investigated. The feasibility is being investigated at sector level and company level. At sector level, feasibility focuses on the availability of alternative fuels, infrastructure and the effect on total CO₂ emissions. At a company level, feasibility focuses on the availability of equipment, applicability in logistics processes and business case.

ZERO EMISSION

Partners:

Category:	knowledge
Capacity:	business case development
Process phase:	FEED-study
Project period:	2020 - 2023
Project costs:	0,7-0,8 M€
Contact:	www.zeroemissiezeeland.nl

HYDRA-2

Safe Flying with Liquid Hydrogen

With flight demonstrations using hydrogen-powered drones NLR takes a new and safe step towards climate neutral aviation contributing to the ambitions of the Sustainable Aviation Agreement and the Hybrid Electric Flight Action Program. In spring 2021, NLR will perform drone (HYDRA-2) test flights using compressed hydrogen as an energy carrier in a fully composite tank. Additionally, fuel cell technology will be demonstrated producing electric power for the propellers. In December 2021, NLR aims to perform a maiden test flight with a drone powered by liquid hydrogen stored in a metal tank. This will be followed by test flights in autumn 2022 with a fully composite liquid hydrogen tank on board.

NLR *Development to Innovation in aerospace*

Partners:

Category:	knowledge, deployment in reality
Capacity:	1 drone
Process phase:	FEED-study, demonstration
Project period:	2021 - 2022
Contact:	leon.fruel@nlr.nl

H2Watt

Production, Transport, Storage and Use of Hydrogen in the Wadden Sea

The Wadden islands of Ameland and Borkum focus on hydrogen as a role model for a sustainable island municipality. H2Watt offers a platform for the realization of various innovation projects for the implementation of hydrogen. Central are methods and systems for the use of hydrogen about production, storage, mobility and heating systems. The test projects include a residential area, the Borkumer IJsselbath and a visitor tent.

H2Watt

Partners:

Category:	knowledge, energy supply
Capacity:	2 projects in 2 countries
Process phase:	feasibility-study
Project period:	2019 - 2022
Project costs:	2,2 M
Contact:	www.h2watt.eu

Brightsite Hydrogen

Development of Plasma Technology on Chemolot for the CO₂-free Production of Hydrogen and Ethylene from Methane

Using electricity as an energy source, a plasma process is being developed for the CO₂-free production of hydrogen, acetylene, ethylene and related hydrocarbons from methane, that can be used in the production of plastics. The aim is to construct a demo plant in 2025 producing 10 t/d of hydrogen and a production plant in 2030 producing 0.2 Mt/yr hydrogen. The business case is potentially positive because it can save on future costs of CO₂ emissions and the use of naphtha for ethylene production.

Brightsite *Transforming Industry*

Partners:

Category:	knowledge
Capacity:	10 - 200 kt H ₂ /yr
Process phase:	concept
Project period:	2021 - 2030
Project costs:	unknown
Contact:	hans.linden@bright.nl

Innovathuis

Realisation of first Hydrogen House in Stad aan 't Haringvliet

The house is the first "normal" house with its own green hydrogen installation. This allows energy to be generated, stored and reused completely independently. The house is also full of other architectural and technical innovations, f.e. home automation and pre-fab walls.

Innovathuis

Partners:

Category:	knowledge
Capacity:	100 kWh storage / 5 kW output
Process phase:	commissioning
Project period:	2019 - 2021
Project costs:	pending
Contact:	www.innovathuis.nl

Hydrohub MW-APC

The Hydrohub MW Test Centre - Advanced Process Control

The Hydrohub MegaWatt Test Center - APC project researches modelling and the impact of variable operation on electrolyser performance and the electricity grid, in addition optimal control strategies are developed for improving overall operational efficiency.

Hydrohub MW Test Center

Partners:

Category:	knowledge
Capacity:	300 kW (2 x 250 kW)
Process phase:	execution
Project period:	2019 - 2022
Project costs:	TKI subsidy
Contact:	carol.klaag@ept.eu

Hydrohub HyChain

Hydrohub - Energy Carriers and Hydrogen Supply Chain

A series of exploratory studies focused on a strategic understanding of the drivers behind global emergence of hydrogen value chains, covering aspects such as sources of supply, demand, transport, costs, environmental impact and public engagement.

Hydrohub

Partners:

Category:	knowledge
Capacity:	> 100 GW
Process phase:	concept
Project period:	2018 - 2021
Project costs:	Energy studies, TKI subsidy
Contact:	carol.klaag@ept.eu

HYREADY

Database on Consequences of Adding H₂ to NG Networks

The HyREADY project aims to encourage the industry to "Be ready for Hydrogen". Practical and uniform engineering guidelines are being developed to support the introduction of hydrogen to the gas grid (from transmission systems to end-users). Results are ready available from a WRI site.

HYREADY

Partners:

Category:	knowledge
Capacity:	scalable
Process phase:	execution
Project period:	2017 -
Project costs:	unknown
Contact:	Albert.vanderhorst@dnv.com

H2 Hub Twente

A Hub for Research, Training and Application of Hydrogen Technology

The H2 Hub Twente is a physical place where entrepreneurs, knowledge institutes and governments work together on technical applications for hydrogen technology. With this initiative, H2 Hub Twente wants to make it possible for SMEs to get started with and realize concrete hydrogen projects. The focus of the hub is on testing and application of hydrogen technology. The added value of the Hub is to support the energy transition by facilitating breakthroughs through scaled research.

H2 Hub Twente

Partners:

Category:	knowledge
Capacity:	scalable
Process phase:	kick off May 2021
Project period:	2019 - 2023
Project costs:	1,2 M€
Contact:	info@h2hubtwente.nl



Knowledge II

Overview

Knowledge I

NG>H₂ District Network

Temporary Conversion from Natural Gas to Hydrogen

It is important to gain knowledge and experience what it takes to convert an existing gas network and homes into hydrogen. In order not to cause inconvenience to residents, but to gain experience, we carry out these activities in vacant demolition houses in Uithoorn.

Category:	knowledge
Capacity:	district network and 14 homes
Process phase:	finished
Project period:	2020 - 2020
Project costs:	unknown
Contact:	frank.vanashpen@edc.nl

Partners: STEVIN, DNV, Feenstra, MPEE, BOSCH, remeha

Groene Waterstof Booster

Developing the hydrogen value chain in the Northern Netherlands and beyond ..

Connecting parties and initiatives, accelerating innovation in the hydrogen chain and making it more sustainable through green hydrogen, and achieving sustainable growth and employment. Create an open innovation climate and promote hydrogen to enable the region to develop into an innovation ecosystem for the transition to green hydrogen. Provide an environment of knowledge and technology for (vocational) education. We provide a testing, demonstration and learning environment in the field of hydrogen.

Category:	knowledge
Capacity:	scalable
Process phase:	execution
Project period:	2020 -
Project costs:	1.2 M subsidy
Contact:	www.groenewaterstofbooster.nl

Missie H2

The Netherlands, a Hydrogen Country

Water is our source of energy. It gives us new possibilities. That is why we choose course and introduce the Netherlands to the sparkling energy of hydrogen. That is our mission, with the athletes of TeamNL, as the driving force to the Tokyo 2021 Olympic Games.

Category:	knowledge, communication
Capacity:	-
Process phase:	execution
Project period:	2020 -
Project costs:	unknown
Contact:	www.missieh2.nl

Partners: Port of Amsterdam, GDSU/ITE, remeha, TOYOTA, Shell

Hydrogen Coalition

For a Sustainable Hydrogen Economy in 2030 in the Netherlands, 39 Organisations Urge NL to Scale Up Investments.

With the recent increase of the European CO2 reduction target to 55%, hydrogen is becoming even more important as a sustainable alternative to fossil resources and fuels and as a buffer for the electricity grid. The next Lower House of Parliament faces the challenge of further future-proofing Dutch climate and energy policy. The starting point here is accelerated upscaling of the hydrogen chain, with the most sustainable possible final scenario.

Category:	knowledge, networking
Capacity:	39 organisations
Process phase:	execution
Project period:	2018 - 2021
Project costs:	2 M
Contact:	www.greenpeace.org

Partners: various logos including RWE, Océ, etc.

H2GO

Towards Hydrogen Energy Island Goeree Overflakkee

H2GO is working on scalable sub-projects concerning production, distribution and demand for green hydrogen in various domains of society. The program has four main objectives: contributing to a reliable energy supply with hydrogen; replacing fossil fuels with hydrogen; reusing the existing natural gas infrastructure for hydrogen; and sharing our expertise and experiences so that it can be duplicated. H2GO applies a divided risk-aid strategy. This gives us room to adapt the strategy as we go, if required.

Category:	knowledge, network
Capacity:	8 projects
Process phase:	concept to execution
Project period:	2017 - 2030
Contact:	www.h2goe.nl

Partners: various logos including TNO, Rijkswaterstaat, etc.

Alkaliboost

Developing Better Alkaline Electrolyser Stacks

The power of alkaline technology is that the electrochemical stacks are relatively cheap, because no expensive or noble metals are used. The committed parties are developing and testing new alkaline stack designs that make it possible to operate at a much higher current density.

Category:	production, knowledge
Capacity:	scalable
Process phase:	concept
Project period:	2018 - 2023
Project costs:	TSE 500 k
Contact:	Gerhard Reijnen, Nouryon

Partners: Nouryon, TU/e

HYDROGREENN

HYDROgen Regional Energy Economy Network Northern NL

Promoting business development of hydrogen applications and sharing hydrogen developments and information in or from the northern Netherlands. The hydrogen applications are used to contribute to the green innovation of energy management, mobility, industry and chemistry, with special attention for the development of education. There are now 450+ members involved.

Category:	knowledge, networking
Capacity:	-
Process phase:	execution
Project period:	2019 - 2023
Project costs:	-
Contact:	info@hydrogreenn.nl

Partners: GDSU/ITE, DNV-GL, TNO, kiwa, New Energy

HyDelta

Research on Obstacles on Hydrogen Deployment

HyDelta is a national cooperation program that removes barriers that delay or halt hydrogen projects. The project that are stranded struggle for example with gaining permits, infrastructural challenges and a lack of clarity about safety regulations.

Category:	knowledge, research
Capacity:	20 man years research capacity
Process phase:	execution
Project period:	start 2020 - april 2021
Project costs:	2 M
Contact:	c.japena@newenergycoalition.org

Partners: GDSU/ITE, DNV-GL, TNO, kiwa, New Energy

Hydrogen House Apeldoorn

Demonstration and Learning Model House for Training Employees

The aim is to initially train approximately fifteen technicians and teach them how to use hydrogen and water networks. They will soon have to be able to apply this in practice, first of all in project Lochem. The house is also intended for the installer of Remeha hydrogen boilers.

Category:	knowledge
Capacity:	1 house
Process phase:	execution
Project period:	2020 - 2021
Project costs:	260 k
Contact:	info@h2allender.com

Partners: autlander, kiwa, remeha

SWITCH

Experimenting with Small-scale Generation of Hydrogen on Farms

TNO and WJLF are starting a hydrogen pilot project in the Pieldeft in Lelystad. Here experiments are being conducted with small-scale generation of hydrogen on farms, using solar and wind energy produced at the same location. In summer 2021 the experiments will start.

Category:	knowledge
Capacity:	small-scale
Process phase:	execution
Project period:	2020 - 2021
Project costs:	1 M
Contact:	pieter.aecon@tno.nl

Partners: ACRRES, TNO



WaterstofLab

HydrogenLab for the Built Environment

The HydrogenLab brings together relevant parties and knowledge to conduct an open dialogue about the following question: “How do we create clarity about the role of hydrogen in the energy mix for the built environment?” The common challenge is to make the built environment CO₂ neutral, at the lowest possible social costs and the greatest possible added value. This requires choices that are made here and now. Anyone who can and wants to contribute to more nuance in the debate about hydrogen in the built environment, and is open to a constructive dialogue, is more than welcome to participate in this (online) hydrogen community.



Category:	knowledge, societal acceptance
Capacity:	70+ members
Process phase:	open for contribution
Project period:	2020 - 2021
Contact:	https://waterstoflab.nl

Partners (initiators):



Zero Emissie Transport Zeeland



The Use of Hydrogen in Transport

This project will encourage companies to introduce Zero Emission Transport into their own business cases. In one of the working packages the role for green hydrogen in heavy transport will be investigated. The feasibility is being investigated at sector level and company level. At sector level, feasibility focuses on the availability of alternative fuels, infrastructure and the effect on total CO₂ emissions. At a company level, feasibility focuses on the availability of equipment, applicability in logistics processes and business case.



Category:	knowledge
Capacity:	business case development
Process phase:	FEED-study
Project period:	2020 - 2023
Project costs:	OPZuid Subsidy
Contact:	www.zero-emissiezeeland.nl



HYDRA-2

Safe Flying with Liquid Hydrogen

With flight demonstrations using hydrogen powered drone's NLR takes a new and safe step towards climate-neutral aviation contributing to the ambitions of the Sustainable Aviation Agreement and the Hybrid Electric Flying Action Program. In spring 2021, NLR will perform drone (HYDRA-2) test flights using compressed hydrogen as an energy carrier in a fully composite tank. Additionally, fuel cell technology will be demonstrated producing electric power for the propellers. In December 2021, NLR aims to perform a maiden test flight with a drone powered by liquid hydrogen stored in a metal tank. This will be followed by test flights in autumn 2022 with a fully composite liquid hydrogen tank on board.

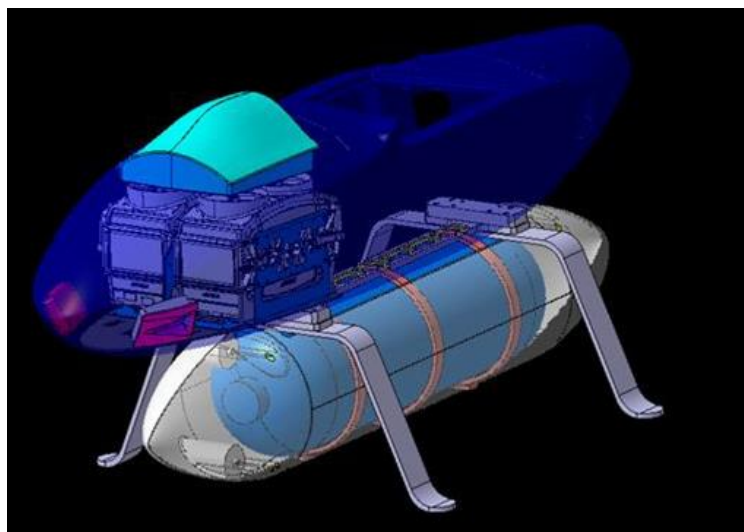

Category:	knowledge, deployment in mobility
Capacity:	1 drone
Process phase:	FEED-study, demonstration
Project period:	2021 - 2022
Contact:	bert.thuis@nlr.nl



Dedicated to innovation in aerospace



Production, Transport, Storage and Use of Hydrogen in the Wadden Sea

The Wadden islands of Ameland and Borkum focus on hydrogen as a role model for a sustainable Island municipality. H2Watt offers a platform for the realization of various innovation projects for the implementation of hydrogen. Central are methods and systems for the use of hydrogen about production, storage, mobility and heating systems. The first projects include a residential area, the Borkumer Inselbahn and a water taxi.



Category:	knowledge, energy supply
Capacity:	2 projects in 2 countries
Process phase:	Feasibility-study
Project period:	2019 – 2022
Project costs:	2.2 M
Contact:	www.h2watt.eu

Partners:



POWERED
BY DUTCH
TECHNOLOGY



Brightsite Hydrogen

Development of Plasma Technology on Chemolot for the CO₂-free Production of Hydrogen and Ethylene from Methane

Using electricity as an energy source, a plasma process is being developed for the CO₂-free production of hydrogen, acetylene, ethylene and related hydrocarbons from methane, that can be used in the production of plastics. The aim is to construct a demo plant in 2025 producing 10 kt / yr hydrogen and a production plant in 2030 producing 0.2 Mt / yr hydrogen. The business case is potentially positive because it can save on future costs of CO₂ emissions and the use of naphtha for ethylene production.

Brightsite
Transforming industry

Category:	knowledge
Capacity:	10 – 200 kt H ₂ / yr
Process phase:	concept
Project period:	2021 – 2030
Project costs:	unknown
Contact:	hans.linden@tno.nl

Partners:



Maastricht University



Brightlands
Chemelot Campus



Innovathuis

Realisation of first Hydrogen House in Stad aan 't Haringvliet

The house is the first "normal" house with its own green hydrogen installation. This allows energy to be generated, stored and reused completely independently. The house is also full of other architectural and technical innovations, f.e. home automation and pre-fab walls.



Category:	knowledge
Capacity:	100 kWh storage / 5 kW output
Process phase:	commissioning
Project period:	2019 - 2021
Project costs:	pending
Contact:	www.innovathuis.nl

Partners:



Hydrohub MW-APC

The Hydrohub MW Test Centre - Advanced Process Control

The Hydrohub MegaWatt Test Center - APC project researches modelling and the impact of variable operation on electrolyser performance and the electricity grid, in addition optimal control strategies are developed for improving overall operational efficiency.



Category:	knowledge
Capacity:	500 kW (2 x 250 kW)
Process phase:	execution
Project period:	2018 - 2022
Project costs:	TKI subsidy
Contact:	carol.xiao@ispt.eu

Partners:



Institute for
Sustainable
Process Technology



university of
 groningen



YOKOGAWA
Co-innovating tomorrow™

TNO innovation
for life
NOBIAN
A Nouryon company

gasunie
GRONINGEN SEAPORTS

FRAMES
Hanzehogeschool
Groningen
University of Applied Sciences



Hydrohub HyChain

Hydrohub - Energy Carriers and Hydrogen Supply Chain

A series of exploratory studies focused on a strategic understanding of the drivers behind global emergence of hydrogen value chains, covering aspects such as sources of supply, demand, transport, costs, environmental impact and public engagement.



Category:	knowledge
Capacity:	> 100 GW
Process phase:	concept
Project period:	2018 - 2021
Project costs:	Energy studies, TKI subsidy
Contact:	carol.xiao@ispt.eu

Partners:



Institute for Sustainable Process Technology



HYREADY

Database on Consequences of Adding H₂ to NG Networks

This HyReady project aims to encourage the industry to “Be ready for Hydrogen”. Practical and uniform engineering guidelines are being developed to support the introduction of hydrogen to the gas grid (from transmission systems to end-users). Results are easily available from a Wiki site.



Category:	knowledge
Capacity:	
Process phase:	execution
Project period:	2017 -
Project costs:	unknown
Contact:	Albert.vandenNoort@dnv.com



H2 Hub Twente

A Hub for Research, Training and Application of Hydrogen Technology

The H2 Hub Twente is a physical place where entrepreneurs, knowledge institutes and governments work together on technical applications for hydrogen technology. With this initiative, H2Hub Twente wants to make it possible for SMEs to get started with and realize concrete hydrogen projects. The focus of the Hub is on testing and application of hydrogen technology. The added value of the Hub is to support the energy transition by facilitating breakthroughs through applied research.



Category:	knowledge
Capacity:	scalable
Process phase:	kick off May 2021
Project period:	2019 - 2023
Project costs:	1.2 M€
Contact:	info@h2hubtwente.nl

Partners:



UNIVERSITY OF TWENTE.



NG>H₂ District Network

Temporary Conversion from Natural Gas to Hydrogen

It is important to gain knowledge and experience what it takes to convert an existing gas network and homes into hydrogen. In order not to cause inconvenience to residents, but to gain experience, we carry out these activities in vacant demolition houses in Uithoorn.



Category:	knowledge
Capacity:	district network and 14 homes
Process phase:	finished
Project period:	2020 - 2020
Project costs:	unknown
Contact:	frank.vanalphen@stedin.net

Partners:

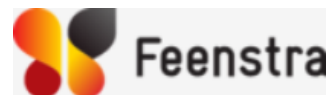

Groene Waterstof Booster



Ministerie van Economische Zaken
en Klimaat

Developing the hydrogen value chain in the Northern Netherlands and beyond ...

Connecting parties and initiatives, accelerating innovation in the hydrogen chain and making it more sustainable through green hydrogen, and achieving sustainable growth and employment. Create an open innovation climate and promote hydrogen to enable the region to develop into an innovation ecosystem for the transition to green hydrogen. Provide an environment of knowledge and technology for (vocational) education. We provide a testing, demonstration and learning environment in the field of hydrogen.



Category:	knowledge
Capacity:	scalable
Process phase:	execution
Project period:	2020 -
Project costs:	1.2 M subsidy
Contact:	www.groenewaterstofbooster.nl



Missie H2

The Netherlands, a Hydrogen Country

Water is our source of energy. It gives us new possibilities. That is why we choose course and introduce the Netherlands to the splashing energy of hydrogen. That is our mission, with the athletes of TeamNL as the driving force to the Tokyo 2021 Olympic Games.



Category:	knowledge, communication
Capacity:	-
Process phase:	execution
Project period:	2020 -
Project costs:	unknown
Contact:	www.missieh2.nl

Partners:



Hydrogen Coalition

For a Sustainable Hydrogen Economy in 2030 in the Netherlands, 39 Organisations Urge NL to Scale Up Investments.

With the recent increase of the European CO2 reduction target to 55%, hydrogen is becoming even more important as a sustainable alternative to fossil resources and fuels and as a buffer for the electricity grid. The next Lower House of Parliament faces the challenge of further future-proofing Dutch climate and energy policy. The starting point here is accelerated upscaling of the hydrogen chain, with the most sustainable possible final scenario.



Category:	knowledge, networking
Capacity:	39 organisations
Process phase:	execution
Project period:	2018 - 2021
Contact:	www.greenpeace.org



H2GO

Towards Hydrogen Energy Island Goeree Overflakkee

H2GO is working on scalable sub-projects concerning production, distribution and demand for green hydrogen in various domains of society. The program has four main objectives: contributing to a reliable energy supply with hydrogen; replacing fossil fuels with hydrogen; reusing the existing natural gas infrastructure for hydrogen; and sharing our expertise and experiences so that it can be duplicated. H2GO applies a directed roll-out strategy. This gives us room to adapt the strategy as we go, if required.



Category:	knowledge, network
Capacity:	8 projects
Process phase:	concept to execution
Project period:	2017 - 2030
Contact:	www.h2goeree-overflakkee.nl

Partners:



Goeree-Overflakkee



TNO innovation for life



WETEC



Alkaliboost

Developing Better Alkaline Electrolyser Stacks

The power of alkaline technology is that the electrochemical stacks are relatively cheap, because no expensive or noble metals are used. The committed parties are developing and testing new alkaline stack designs that make it possible to operate at a much higher current density.



Category:	production, knowledge
Capacity:	scalable
Process phase:	concept
Project period:	2018 - 2023
Project costs:	TSE 500 k
Contact:	Gerhard Remmers, Nouryon

Partners:

Nouryon

TU/e EINDHOVEN
UNIVERSITY OF
TECHNOLOGY



HYDROGREENN

HYDROGen Regional Energy Economy Network Northern NL

Promoting business development of hydrogen applications and sharing hydrogen developments and information in or from the northern Netherlands. The hydrogen applications are used to contribute to the green innovation of energy management, mobility, industry and chemistry, with special attention for the development of education.. There are now 450+ members involved.



Category:	knowledge, networking
Capacity:	-
Process phase:	execution
Project period:	2019 - 2023
Project costs	-
Contact:	info@vnoncw-mkbnoord.nl



HyDelta

Research on Obstacles on Hydrogen Deployment

HyDelta is a national cooperation program that removes barriers that delay or halt hydrogen projects. The project that are stranded struggle for example with gaining permits, infrastructural challenges and a lack of clarity about safety regulations.



Category:	knowledge, research
Capacity:	20 man years research capacity
Process phase:	execution
Project period:	start 2020 - april 2021
Project costs:	2 M
Contact:	c.jepma@newenergycoalition.org

Partners:

The logo for gasunie, consisting of the word "gasunie" in a lowercase, sans-serif font.

The logo for DNV GL, featuring three horizontal lines (blue, green, blue) above the text "DNV GL" in a bold, sans-serif font.

The logo for TNO, consisting of the letters "TNO" in a bold, black, sans-serif font.

The logo for TKI NIEUW GAS Topsector Energie, featuring a cluster of orange dots above the text "TKI NIEUW GAS" and "Topsector Energie" in a smaller font.

The logo for kiwa, featuring the word "kiwa" in a bold, blue, sans-serif font next to a red square containing a white silhouette of a kiwi bird.

The logo for New Energy Coalition, featuring the words "New Energy" in a large, bold, sans-serif font above the word "Coalition" in a smaller font.



Hydrogen House Apeldoorn

Demonstration and Learning Model House for Training Employees

The aim is to initially train approximately fifteen technicians and teach them how to use hydrogen and water networks. They will soon have to be able to apply this in practice, first of all in project Lochem. The house is also intended for the installer of Remeha hydrogen boilers.



Category:	knowledge
Capacity:	1 house
Process phase:	execution
Project period:	2020 - 2021
Project costs:	240 k
Contact:	info@alliander.com

Partners:



Experimenting with Small-scale Generation of Hydrogen on Farms

TNO and WUR are starting a hydrogen pilot project in the Fieldlab in Lelystad. Here experiments are being conducted with small-scale generation of hydrogen on farms, using solar and wind energy produced at the same location. In summer 2021 the experiments will start.



Category:	knowledge
Capacity:	small-scale
Process phase:	execution
Project period:	2020 - 2021
Project costs:	1 M
Contact:	peter.eecen@tno.nl

Partners:

